



User Manual

HD Outdoor Fixed Dome Camera with Color Night Vision

DCS-6315

Preface

D-Link reserves the right to revise this publication and to make changes in the content hereof without obligation to notify any person or organization of such revisions or changes. Information in this document may become obsolete as our services and websites develop and change.

Manual Revisions

Revision	Date	Description
1.00	January 6, 2014	DCS-6315 Revision A1 with firmware version 1.00

Trademarks

D-Link and the D-Link logo are trademarks or registered trademarks of D-Link Corporation or its subsidiaries in the United States or other countries. All other company or product names mentioned herein are trademarks or registered trademarks of their respective companies.

Copyright © 2014 D-Link Corporation.

All rights reserved. This publication may not be reproduced, in whole or in part, without prior express written permission from D-Link Corporation.

Table of Contents

Product Overview.....	4	Network Setup.....	37
Package Contents.....	4	Dynamic DNS.....	40
Introduction.....	5	Image Setup.....	41
System Requirements.....	5	Audio and Video.....	43
Features.....	6	Preset.....	45
Hardware Overview.....	7	Motion Detection.....	47
Front.....	7	Time and Date.....	48
Top.....	8	Event Setup.....	49
Cable Harness.....	9	SD Card.....	57
Internal.....	10	Advanced.....	58
Assembly and Installation.....	11	Digital Input/Output.....	58
Installing a microSD Card.....	11	ICR and IR.....	59
Deploying the Camera.....	13	HTTPS.....	60
Mounting the Camera.....	15	Access List.....	61
Attaching the Camera to the Pendant Mount.....	18	Maintenance.....	62
Attaching the Camera to the Bent Mount.....	20	Device Management.....	62
Orienting the Camera.....	22	System.....	63
Camera Installation Wizard.....	23	Firmware Upgrade.....	64
General Connection Using 12 V DC Power		Status.....	65
Adapter.....	23	Device Info.....	65
Connection Using Power over Ethernet (PoE).....	24	Logs.....	66
Software Installation.....	25	Help.....	67
Configuration.....	28	DI/DO Specifications.....	68
Using the Configuration Interface.....	28	Technical Specifications.....	69
Live Video.....	29		
Setup.....	31		
Setup Wizard.....	31		

Product Overview

Package Contents



DCS-6315 HD Outdoor Fixed Dome Camera



CD-ROM with User Manual and Software



Quick Install Guide



Power Adapter



Security Wrench



CAT5 Ethernet cable



Screws and Wall Socket



Weather Shield

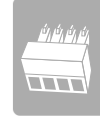

4-Pin Terminal Block

If any of the above items are missing, please contact your reseller.

Note: *Using a power supply with a different voltage than the one included with your product will cause damage and void the warranty for this product.*

Safety Notice:

Installation and servicing should be done by certified technicians so as to conform to all local codes and prevent voiding your warranty.

Introduction

The DCS-6315 HD Outdoor Fixed Dome Camera with Color Night Vision is a professional surveillance and security solution for small, medium, and large enterprises. The DCS-6315 uses a 1.3 megapixel progressive scan CMOS sensor which produces high quality images with low noise. This makes it ideal for surveillance applications. Since the DCS-6315 has Wide Dynamic Range (WDR) enhancement, users can identify image details in both extremely bright and dark conditions.

The DCS-6315 has an IP68 certified weatherproof housing, designed for both indoor and outdoor use. The built-in removable IR-cut filter and IR LEDs give the DCS-6315 the ability to view up to 15 meters (49 feet) at night. The camera supports Power over Ethernet (PoE), allowing for easy installation, without the need for supplemental power cabling. This combination of features makes the DCS-6315 a high-performance, reliable and cost-effective 24-hour megapixel surveillance solution.

System Requirements

- Computer with Microsoft Windows® 8, 7, Vista®, or XP (for CD-ROM Setup Wizard), Mac OS® X or Linux
- PC with 1.3GHz processor or above, and at least 128MB RAM
- Internet Explorer® 7 or above , Firefox® 3.5 or above, Safari® 4 and Chrome™ 8.0 or above
- Existing 10/100 Ethernet-based network
- A microSD memory card (optional) is required for recording to onboard storage. SDHC Class 6 or above is recommended.
- Broadband Internet connection

Features

Wide Dynamic Range

Wide Dynamic Range technology corrects imperfect lighting conditions, providing clear images with the right amount of contrast even when a subject is backlit

Remote Monitoring Utility

The D-ViewCam application adds enhanced features and functionality for the DCS-6315 and allows administrators to configure and access the Network Camera from a remote site via Intranet or Internet. Other features include image monitoring, recording images to a hard drive, viewing up to 32 cameras on one screen, and taking snapshots.

IR LED for Day and Night Functionality

The built-in infrared LEDs enables night time viewing of up to 15 meters (49 feet).

IP68 Weatherproof Housing

The DCS-6315 uses an IP68 weatherproof housing, which means you to rest assured that even under the toughest conditions, your camera will continue to provide round-the-clock surveillance.

PoE (Power over Ethernet) for Streamlined Installation

The DCS-6315 can get all the power it needs from a PoE switch or PoE injector, for a simple and clutter-free installation.

All-Day Surveillance with low light color image capability

The built-in Sony sensor allows you to monitor an area during the night with full color images.

Hardware Overview

Front



1	Light Sensor	The light sensor measures the lighting conditions and switches between color and infrared accordingly
2	Camera Lens	Vari-focal lens records video of the surrounding area
3	IR LEDs	Infrared LEDs illuminate the camera's field of view at night
4	Power/Status LED	Status LED indicates the camera's current status

Top

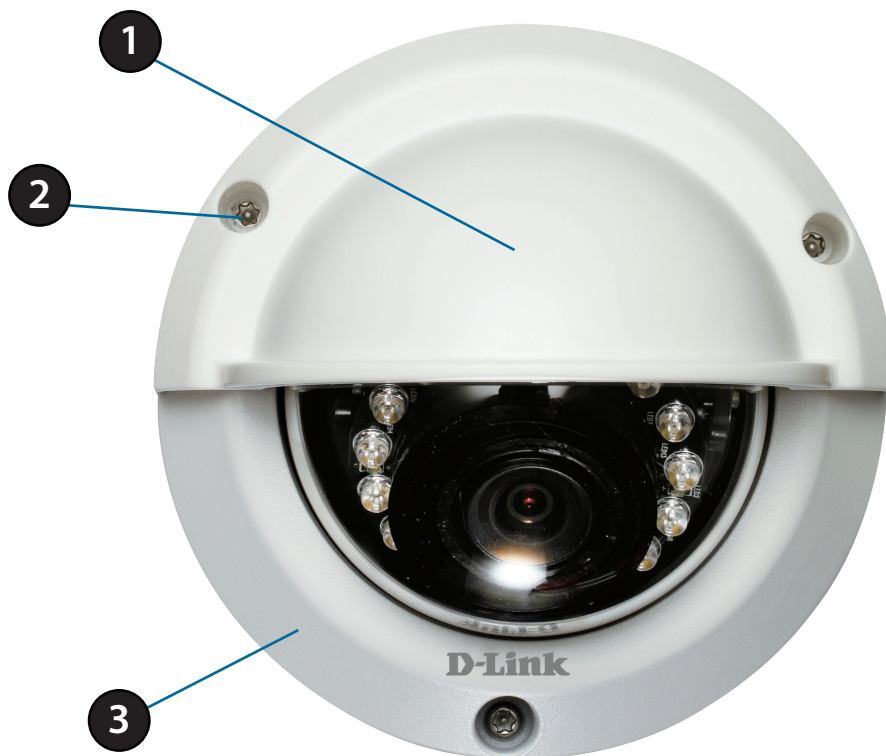

1	Weather Shield	Shields the camera sensor from direct sunlight.
2	Adjustment Screw	Used to secure the weather shield to the camera.
3	Bottom Camera Shoe	Used to attach to the optional mounting accessories.

Note: When the weather shield is attached, you may see reflections in the video if the IR LEDs are turned on and the camera is at a high angle. If you experience this, you should lower the angle of the camera or turn off the IR LEDs. For details on how to adjust the camera angle, refer to ["Orienting the Camera" on page 22](#). For details on how to turn the IR LEDs on/off, refer to ["ICR and IR" on page 59](#).

Cable Harness

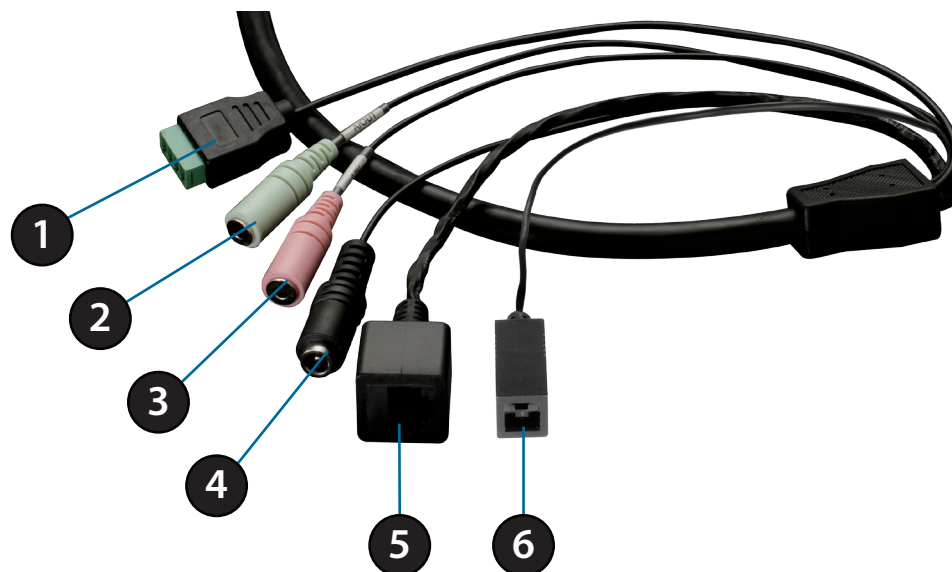

1	DI/DO Connector	I/O connectors for external devices. (12V DC output.)
2	Audio Out (Green)	Connects to a speaker.
3	Audio In (Red)	Connects to a microphone.
4	Power Connector	Power connector for the provided 12V DC power adapter.
5	Ethernet Jack	Connects to an RJ45 Ethernet port. Can be used with PoE to provide power to the camera.
6	Reset Button	Press and hold the recessed button for 10 seconds to reset the camera.

Internal

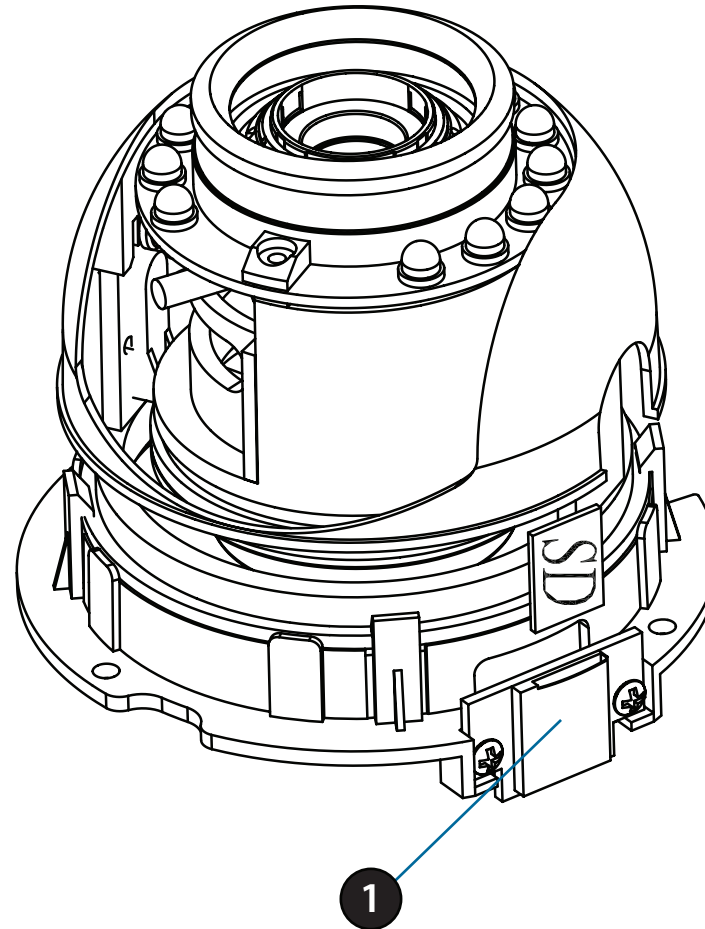

1	microSD Card Slot	Insert a microSD card for storing recorded images and video
---	--------------------------	---

Note: For step-by-step instructions on how to insert a microSD card, skip to "[Installing a microSD Card](#)" on page 11. This camera currently supports SDXC (Secure Digital eXtended Capacity) cards up to 64GB, in FAT32 format only.

Assembly and Installation

Installing a microSD Card

Step 1

Place the camera base-down on a non-slip flat surface.

Step 2

Remove the three retaining screws, which will allow you to remove the adjustable top part of the camera housing.

Step 3

Remove the base of the camera by holding the camera firmly and rotating the base in a counter clockwise direction.

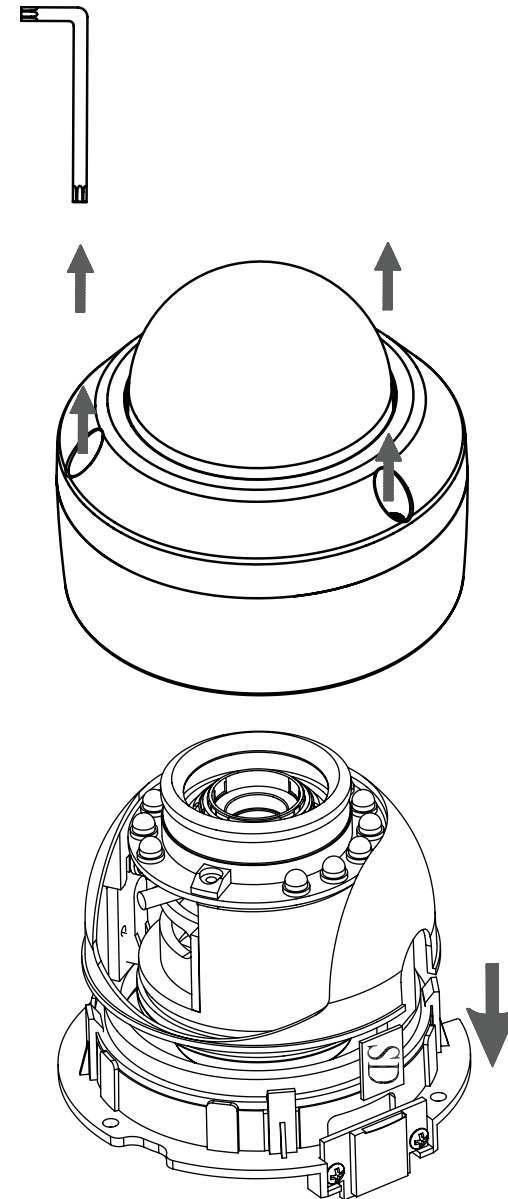

Step 4

Insert your microSD memory card into the slot, making sure the notch is oriented toward the front of the camera.

Step 5

Replace the base of the camera by holding the camera firmly and rotating the base in a clockwise direction ensuring a tight fit.

Note: Make sure that the weatherproof seals are secured firmly in place.

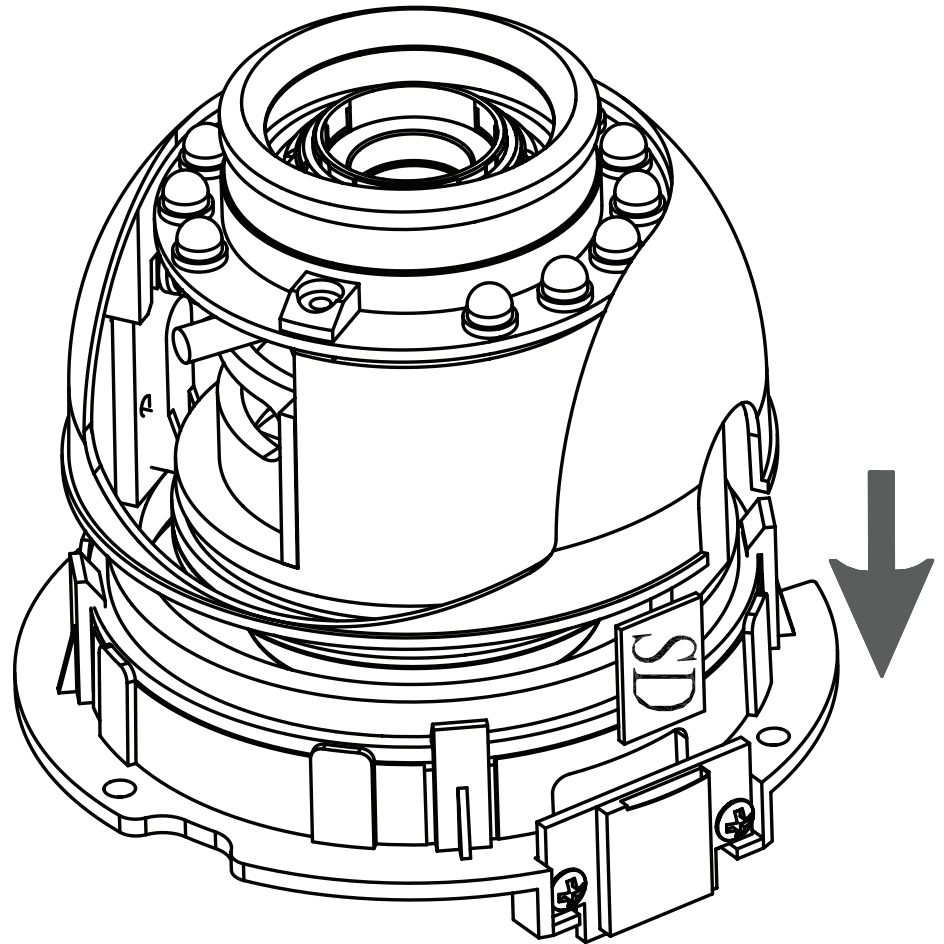

Deploying the Camera

Note: Before deploying the camera to a fixed location, you should take a photo from the intended location to make sure the camera will have an adequate field-of-view.

Step 1

Place the *Alignment Sticker* in the intended location for your camera, making sure you allow sufficient space for both the DCS-6315 and the wire-in bracket. You can refer to the diagrams for "[Dimensions](#)" on page 71.

Step 2

Use a 6mm drill bit to make required holes approximately 30mm deep.

Step 3

Remove the *Alignment Sticker*.

Step 4

Insert wall anchors and attach the mounting plate, using the screws provided.

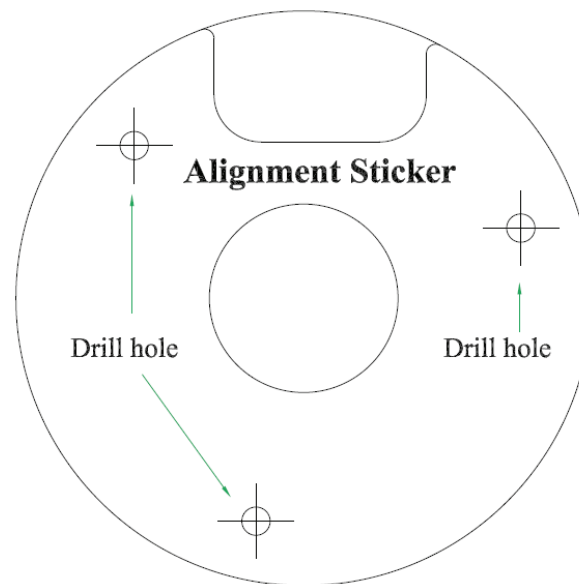

Step 5

Fasten the camera firmly to the mounting plate using the screw provided. Make sure the cables are routed through the cable channel or via the mounting plate cut-out.

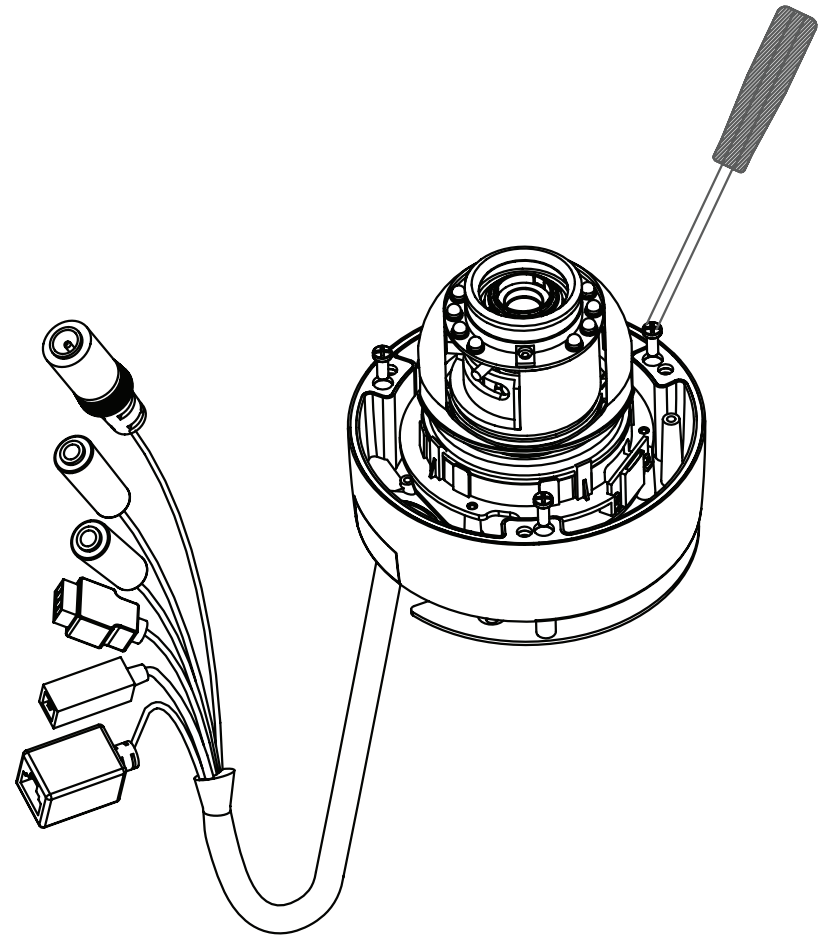

Mounting the Camera

There are several methods for mounting the DCS-6315 to a wall or ceiling:

- Mount Camera Directly to a Wall or Ceiling
- Attach Camera to Pendant Mount
- Attach Camera to Bent Mount

Step 1

Use the included security wrench to unscrew the three retaining screws, and then remove the top part of the camera housing.

Step 2

Next you must use a screwdriver to remove the bottom mounting plate from the lower half of the camera housing. The mounting plate is secured with three screws positioned around the outer edge of the lower part of the camera housing.

If you will be mounting the camera directly to a wall or ceiling, please continue to the next page.

If you will be mounting the camera using the pendant mount, please refer to ["Attaching the Camera to the Pendant Mount"](#) on page 18.

If you will be mounting the camera using the bent mount, please refer to ["Attaching the Camera to the Bent Mount"](#) on page 20.

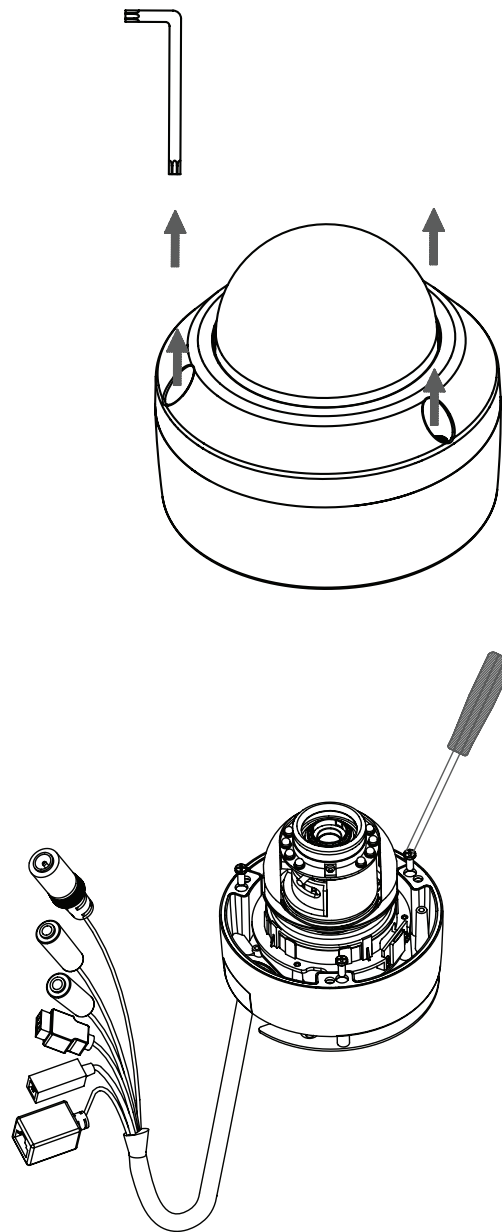

Step 3

After remove the mounting plate from the lower half of the camera housing, the DCS-6315 can be attached to a wall or ceiling using the *Alignment Sticker*. Refer to "[Deploying the Camera](#)" on page 13.

If you will be installing the camera onto a surface that cannot house the cable, the cable access part can be removed so that the cable can exit the camera housing easily. Once the mounting plate has been removed, you will be able to remove the cable access panel.

If you will be routing the connection cables through a wall or ceiling, you should leave the cable access part attached, as it will help protect the cable from vandalism.

Step 4

Slide the lower half of the camera housing onto the mounting plate and re-secure it. Make sure that the cable sheath extends out of the base in a way that ensures the cable is not kinked or twisted.

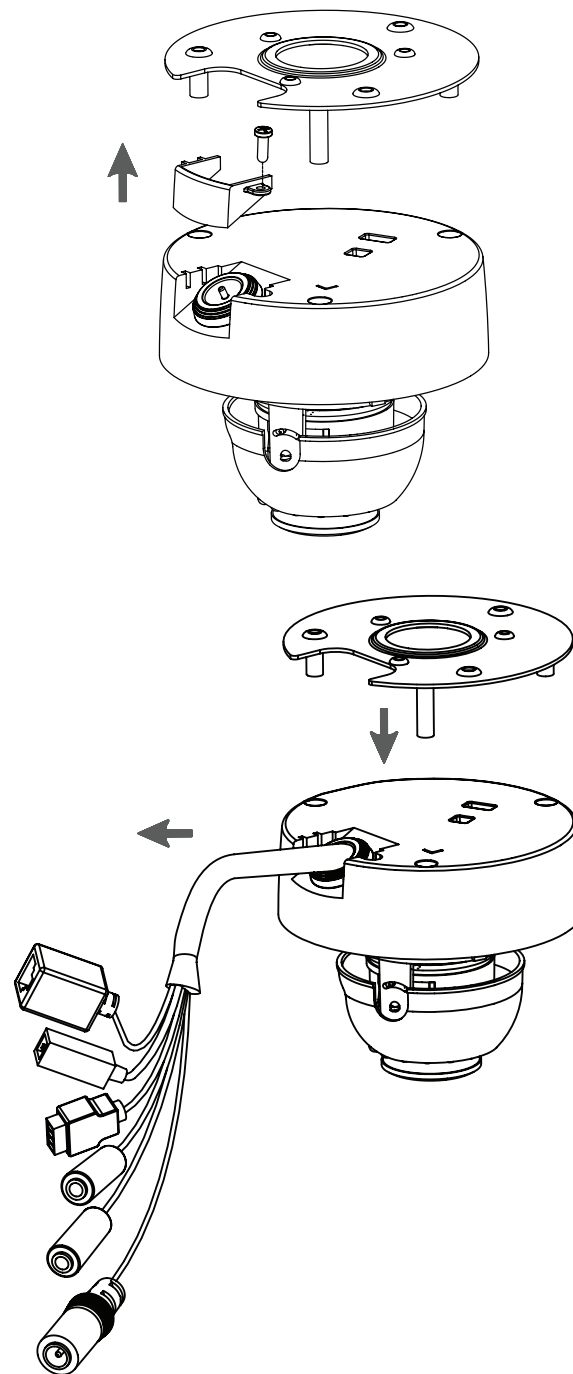

Step 5

Reattach the top part of the camera housing, and secure it by tightening the three retaining screws.

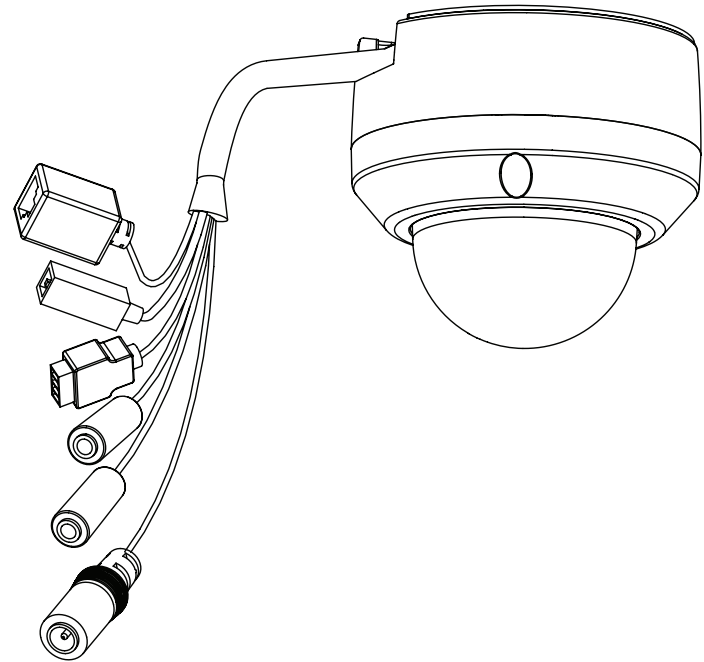

Step 6

If needed, the included weather shield may now be attached to the camera.

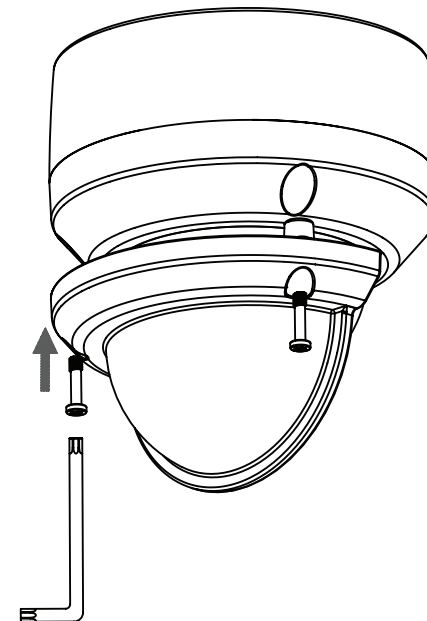

Attaching the Camera to the Pendant Mount

Step 1

The mounting plate that you removed from the lower part of the camera housing must be attached to the bracket cap, using the three screws as shown in the diagram.

Step 2

Use the included *Alignment Sticker* for marking the mounting holes on the ceiling. Drill the corresponding holes. For more details, see "[Deploying the Camera](#)" on page 13.

Step 3

Place the rubber seal onto the mounting part of the pendant bracket. Securely mount the rubber seal and pendant bracket to the ceiling.

Step 4

Attach the bracket cap, by screwing it onto the pendant bracket.

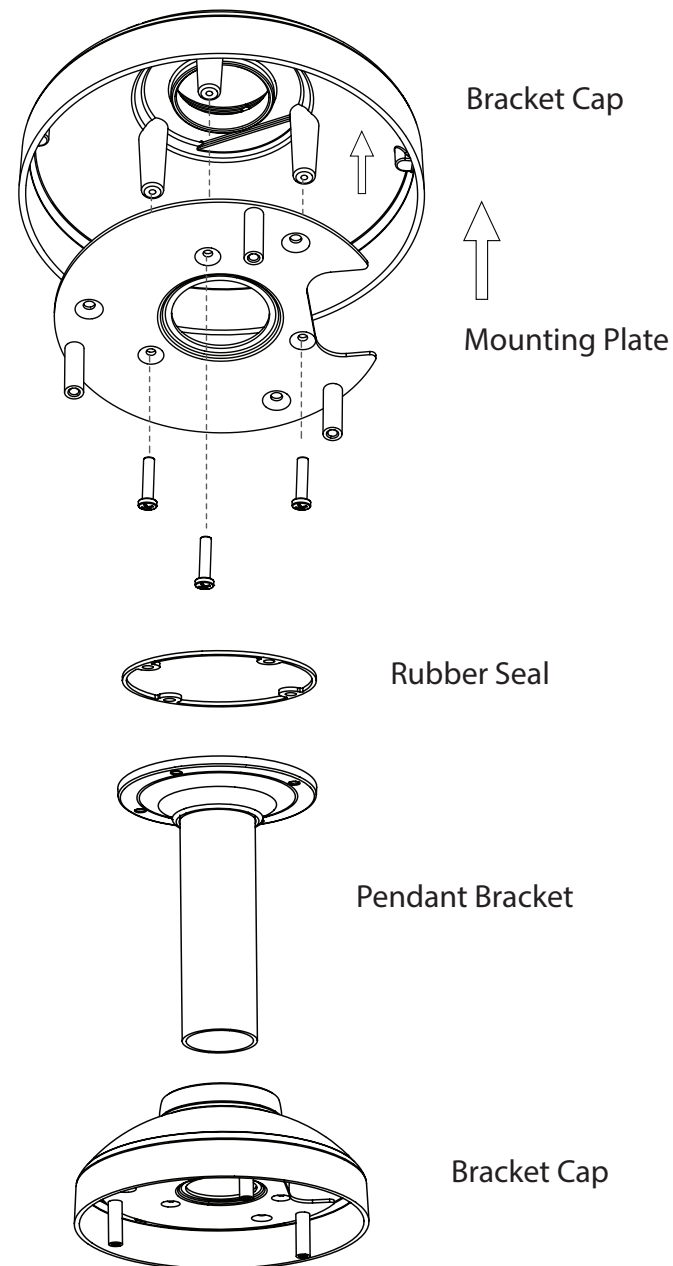

Step 5

Reattach the bottom part of the camera housing, by first pushing the cable sheath up through the pendant mount. Once the cable has been pushed through, you can then firmly reattach the bottom part of the camera housing, and secure it by tightening the three retaining screws.

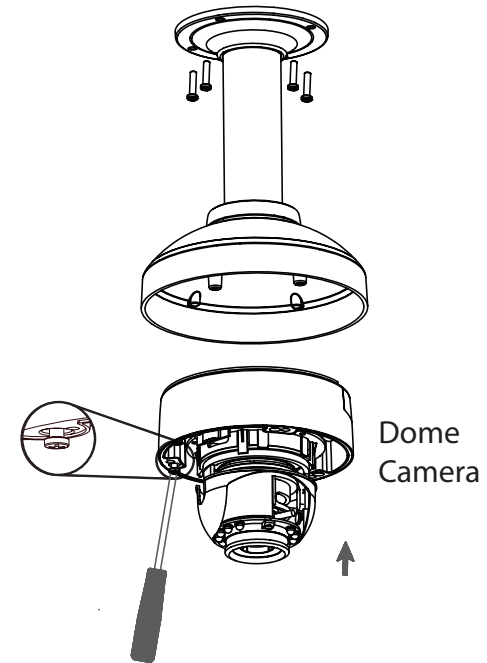

Step 6

Reattach the top part of the camera housing, and secure it by tightening the three retaining screws.

If needed, the included weather shield may now be attached to the camera. See the diagram in **Step 6** of "[Mounting the Camera](#)" on page 15.

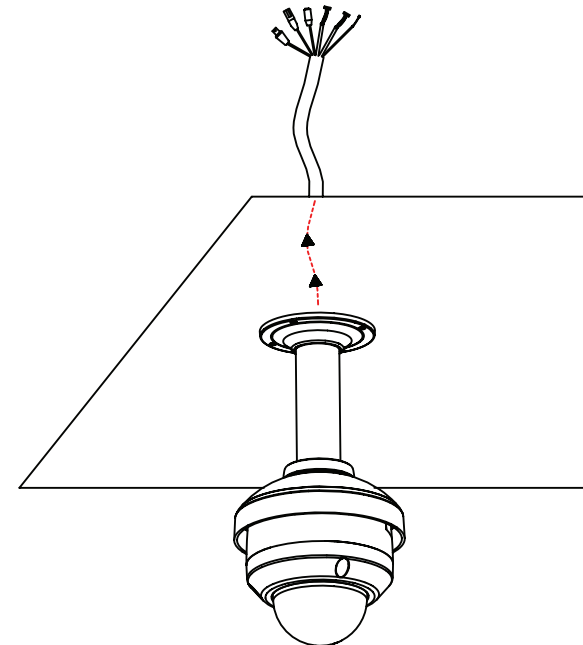

Attaching the Camera to the Bent Mount

Step 1

The mounting plate that you removed from the lower part of the camera housing must be attached to the bracket cap, using the three screws as shown in the diagram.

Step 2

Use the included *Alignment Sticker* for marking the mounting holes on the ceiling. Drill the corresponding holes. For details, see "[Deploying the Camera](#)" on page 13.

Step 3

Place the rubber seal onto the mounting part of the bent bracket. Securely mount the rubber seal between the bent bracket and the ceiling.

Step 4

Attach the bracket cap, by screwing it onto the bent bracket.

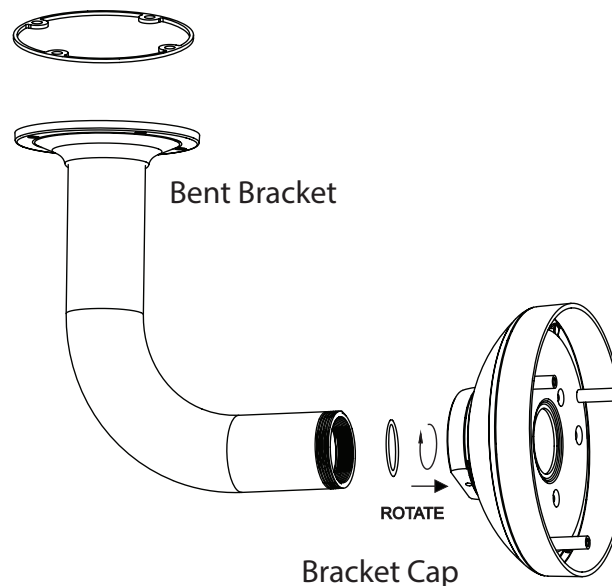
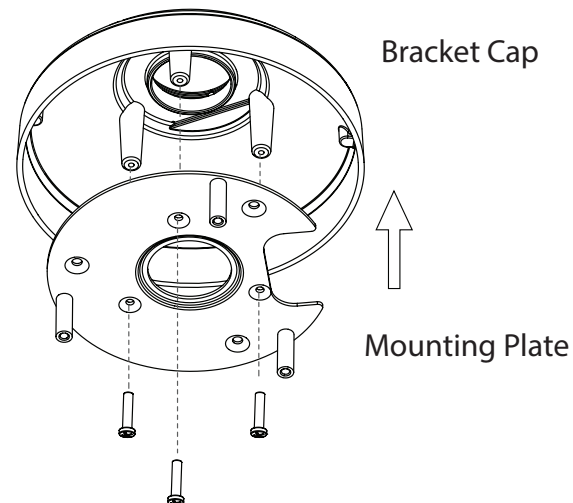

Step 5

Reattach the bottom part of the camera housing, by first pushing the cable sheath up through the bent mount. Once the cable has been pushed through, you can then firmly reattach the bottom part of the camera housing. Secure it by tightening the three retaining screws.

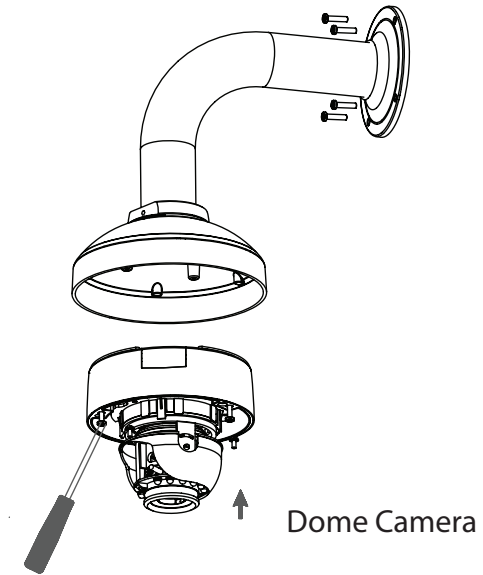

Step 6

Reattach the top part of the camera housing, and secure it by tightening the three retaining screws.

If needed, the included weather shield may now be attached to the camera. See the diagram in **Step 6** of "[Mounting the Camera](#)" on page 15.

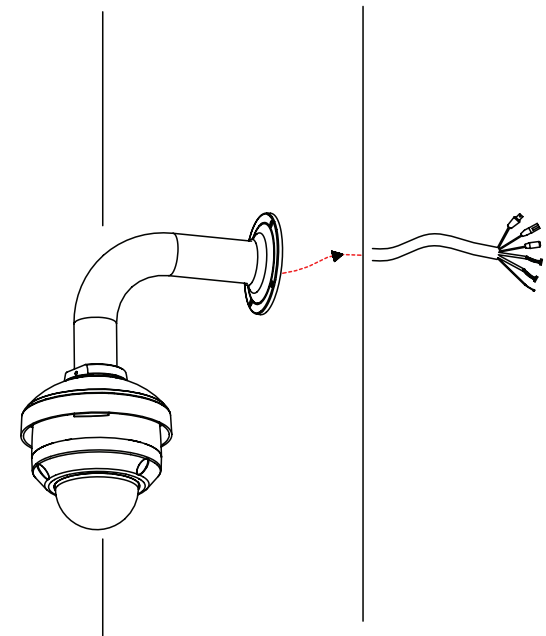

Orienting the Camera

The DCS-6315 can be adjusted to maintain the optimum view when mounted to a wall by following the steps below:

Step 1

Turn the lens module to the left and to the right until you find the preferred position.

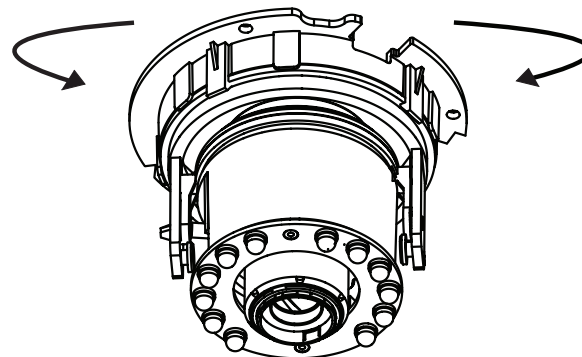

Step 2

Loosen the tilt screws on both sides of the camera, and tilt the lens module up and down until you find the preferred position.

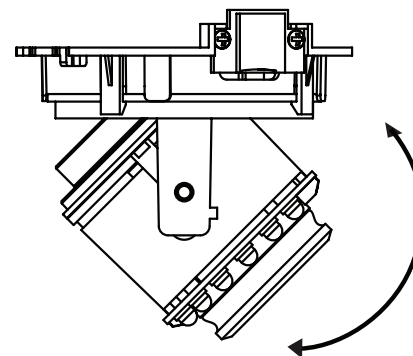

Step 3

Turn the lens to adjust the IP camera's image until the desired orientation is achieved.

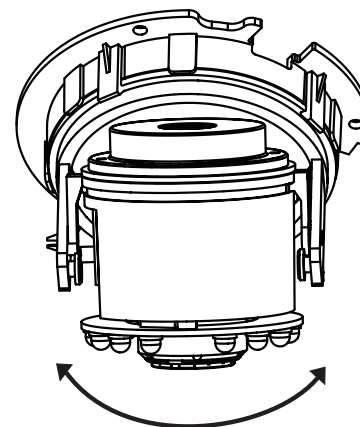

Camera Installation Wizard

General Connection Using 12 V DC Power Adapter

Step 1

Use an Ethernet cable to connect the network camera to a switch.

Step 2

Connect the supplied power adapter from the power connector on the camera to a power outlet.

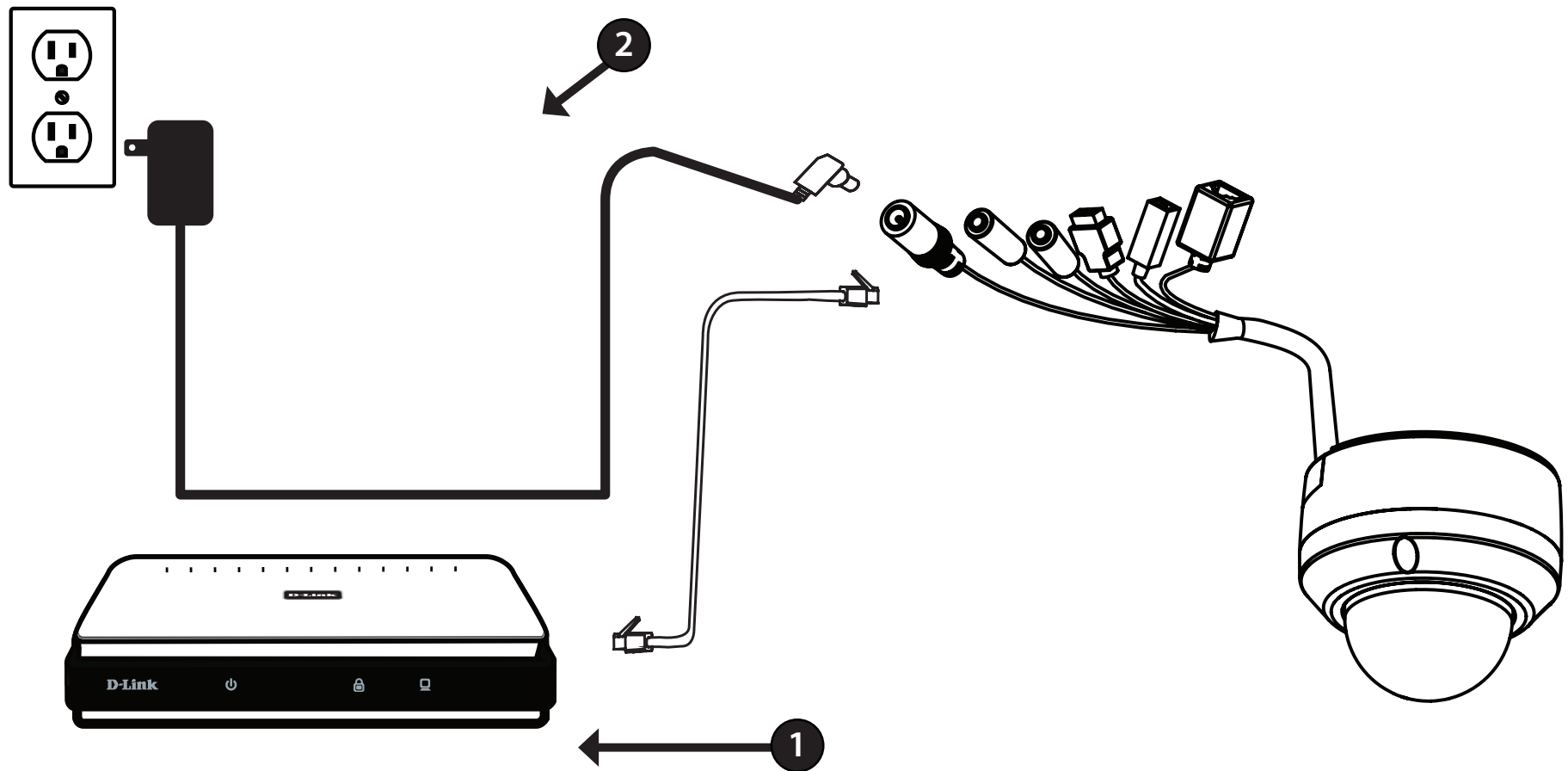

Connection Using Power over Ethernet (PoE)

Step 1

If you are using a PoE switch, use an Ethernet cable to connect the Ethernet Jack on the IP camera to the switch. This will enable the transmission of both power and data over a single cable.

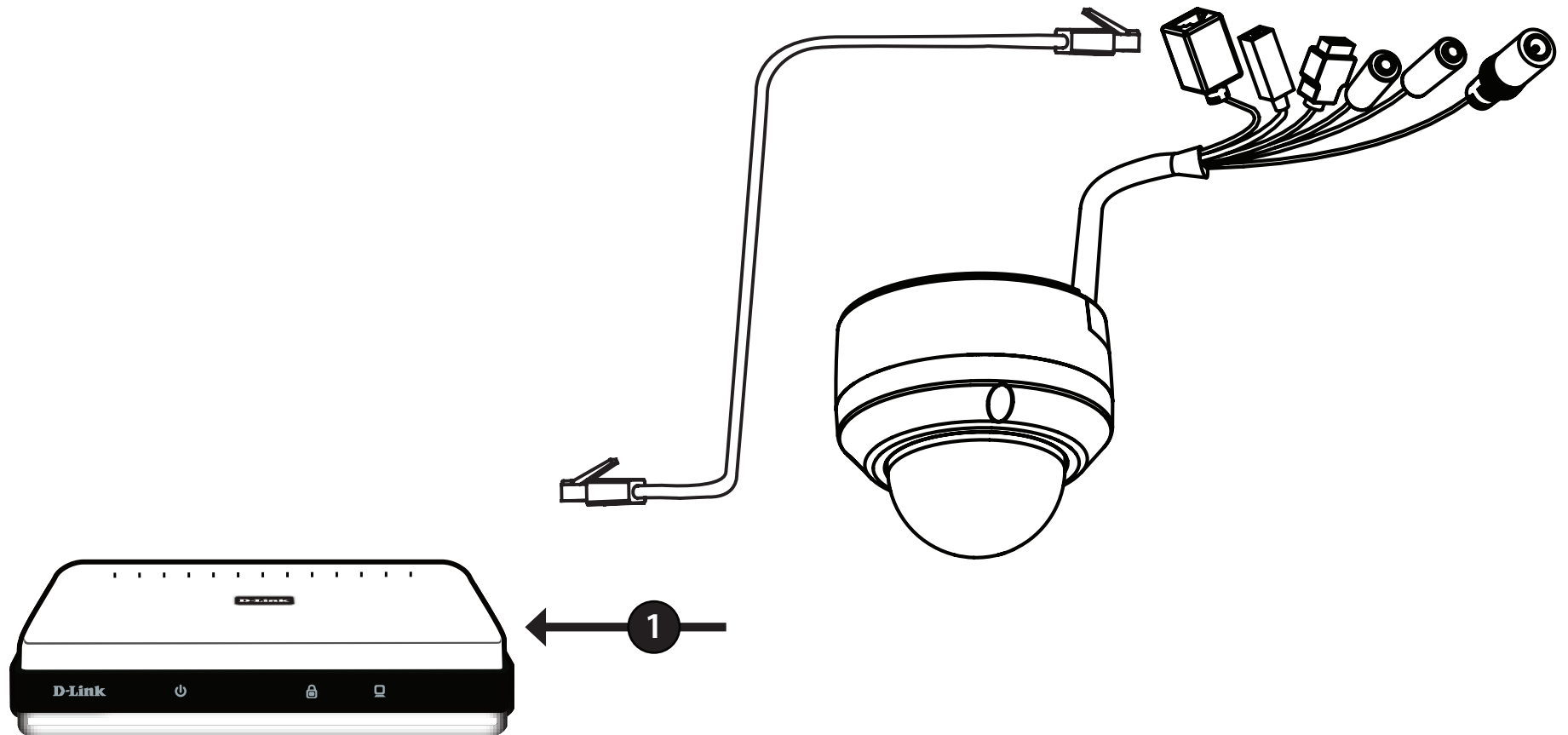

Software Installation

Step 1

Insert the Installation CD-ROM into your computer's CD drive to start the autorun program. This will launch the *Camera Installation Wizard*. The *Setup Wizard* will guide you through the installation process of configuring your camera.

Note: If the autorun program does not automatically start on your computer, go to **Windows**, click **Start > Run**. In the Run command box type **D:\setup.exe**, where D: represents your CD-ROM drive.

Step 2

You must accept the *End User Licence Agreement* and follow the on-screen prompts to install the *Camera Installation Wizard*.

Step 3

Select your camera from the list, then click **Wizard**. If you have multiple cameras, you can identify them using the MAC ID that is printed on the label attached to the back of your camera.

The screenshot displays two windows from the D-Link camera installation software. The top window is titled "D-Link HD OUTDOOR FIXED DOME CAMERA WITH COLOR NIGHT VISION". It features a menu on the left with options: "Setup Wizard", "View Documentation", "Install D-ViewCam", and "Support". A central image shows a white dome camera. The bottom window is titled "D-Link Building Networks for People SECURICAM Network". It contains a table with the following data:

MAC Address	Current IP Address	Device Name
0a 4a ca 6a ca 0b	192.168.0.102	DCS-6315

Below the table are buttons for "Wizard", "Search", "Link", "About", and "Exit".

Step 4

By default the *Admin ID* is **admin** and the password field is blank. It is recommended that you create and confirm a **Password** for your camera.

Click **Next** to continue.

The screenshot shows the 'Set up an Admin ID and Password to secure your camera.' screen. At the top, there is a D-Link logo and the 'SECURICAM Network' header. The main instruction is 'Set up an Admin ID and Password to secure your camera. Click Next to continue.' Below this, there are two columns of input fields. The first column has 'Admin ID' and 'Password' fields. The second column has 'New ID', 'New Password', and 'Reconfirm' fields. Each of these second-column fields has a 'Change' checkbox to its left. At the bottom right, there are three buttons: 'Back' (left arrow), 'Next' (right arrow), and 'Exit' (stop sign).

Step 5

Select **Static IP** if you want to manually enter the network settings supplied by your Internet Service Provider (ISP). Select **DHCP** (Dynamic IP) if you want your router or DHCP server to automatically assign the camera its network settings.

Note: You may select **DHCP** if you are unsure of which method to choose.

Click **Next** to continue.

The screenshot shows the 'Set IP Address' screen. At the top, there is a D-Link logo and the 'SECURICAM Network' header. The main instruction is 'Set IP Address'. Below this, there are two radio button options: 'DHCP' (which is selected) and 'Static IP'. Under the 'Static IP' option, there are five input fields: 'IP Address', 'Subnet Mask', 'Default Gateway', 'Primary DNS', and 'Secondary DNS'. At the bottom right, there are three buttons: 'Back' (left arrow), 'Next' (right arrow), and 'Exit' (stop sign).

Step 6

Confirm your camera's login details and settings, and then click **Restart**.

The LED on the front of the DCS-6315 will blink, then turn solid green once it successfully connects to your network.

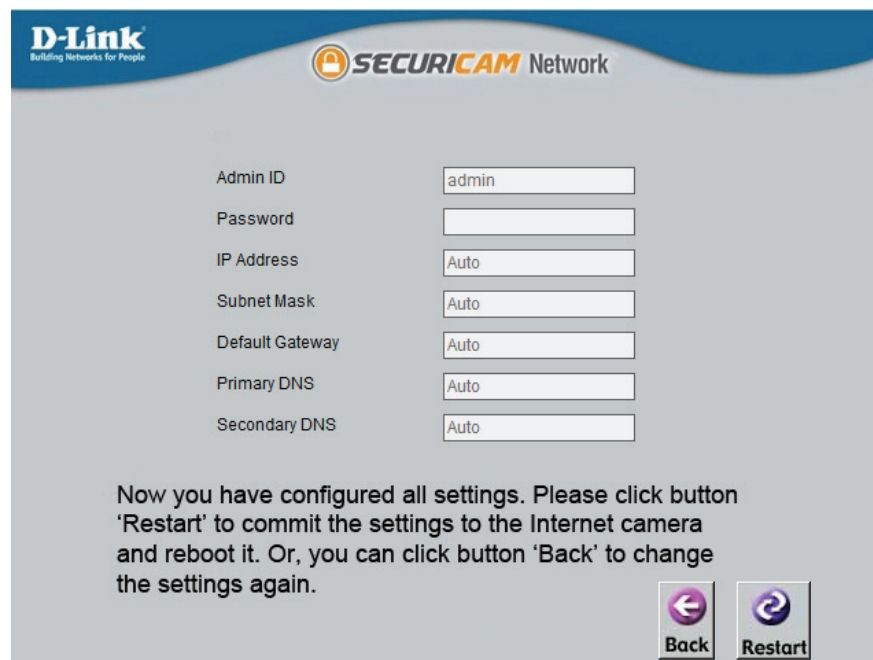

Step 7

Your camera setup is complete. Click **Exit** to exit the wizard. You can skip to "[Configuration](#)" on page 28 for advanced configuration of your camera.

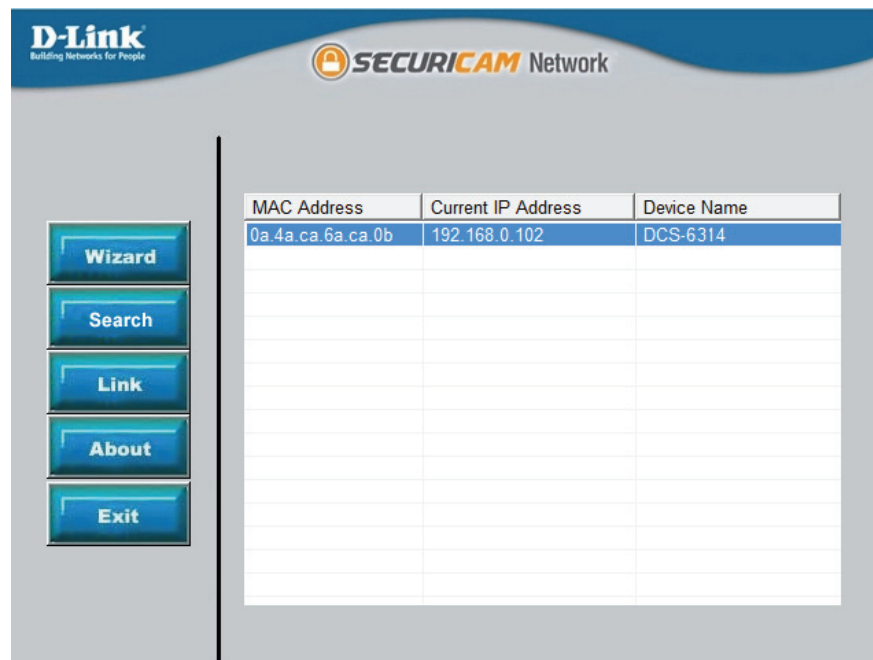

Configuration

Using the Configuration Interface

When you complete the *Camera Installation Wizard*, you are ready to begin using your camera. The camera's built-in Web configuration utility is designed to allow you to easily access and configure your DCS-6315.

Step 1

Click the **Link** button at the end of the *Camera Installation Wizard*.* The wizard will automatically open your web browser to the IP address of the camera.

***Note:** You can also enter the **IP address** of your camera into a web browser, such as Mozilla Firefox.

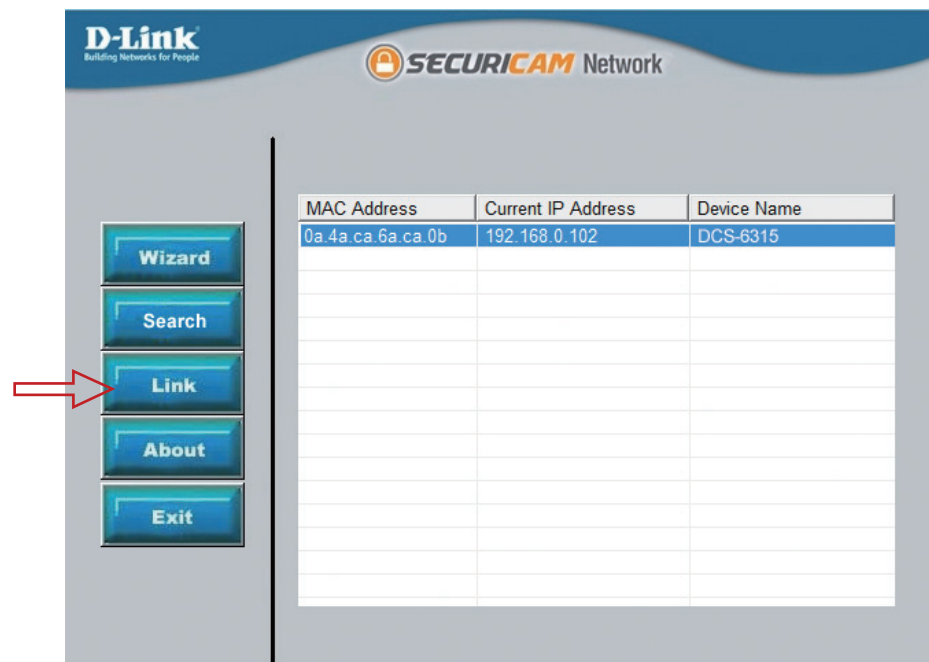

Step 2

Enter your **User name (admin)** and the **Password** you created with the *Installation Wizard* to access the configuration interface. If you did not create a password, the default password is blank.

Click **OK**.



Live Video

This section explains your camera's *Live Video*. You may select any of the available icons listed below to operate the camera.

You can zoom in and out on the *Live Video* image using your mouse.

- Right-click to zoom out
- Left-click to zoom in

SD Status: This option displays the status of the microSD card. If no microSD card has been inserted, this screen will display the message, *Card Invalid*.

IO Status: This field displays the status of your I/O device if a device has been connected. Otherwise, it says *None*.

ePTZ Speed: You may select a value between zero and 10 for ePTZ (electronically Pan, Tilt, and Zoom). Zero is the slowest and 10 is the fastest.







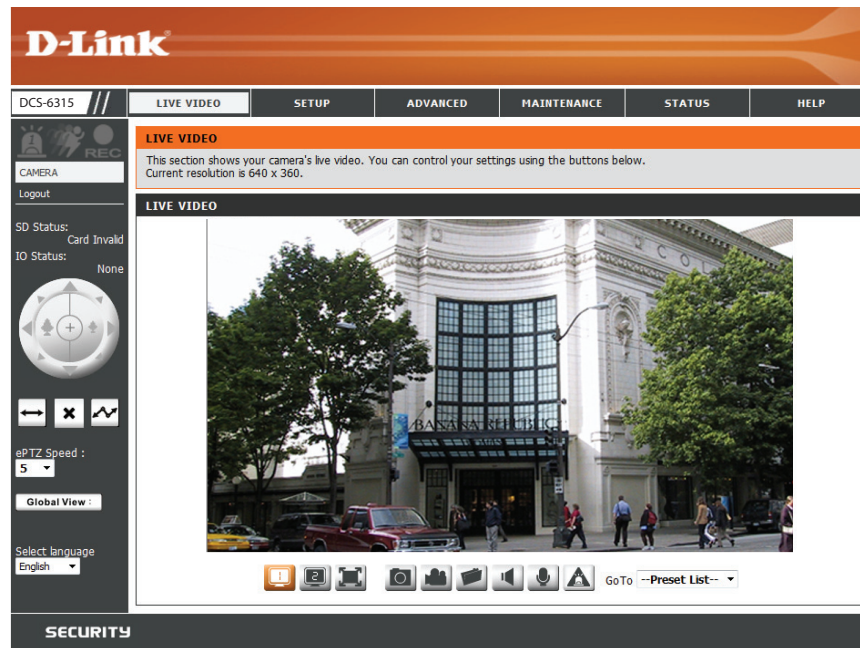









Global View: This window indicates the total field of view (FOV) of the camera. The red box indicates the visible region of interest (ROI). This option will only be present if the view window size is set to be smaller than the current frame size. You can find more information on how to set the frame size and view window area in "[Audio and Video](#)" on page 43.

Select Language: You may select a different language for the UI using this drop-down menu.

Go To (-Preset List-) If any presets have been defined, selecting a preset from this list will display it.



Section 3: Configuration

	Digital Input Indicator	This indicator will change color when a digital input signal is detected.
	Motion Trigger Indicator	This indicator will change color when a trigger event occurs. Note: <i>The video motion feature must be enabled.</i>
	Recording Indicator	This indicator will change color when a recording is in progress.
	Control Pad	This control pad can be used to electronically Pan, Tilt, and Zoom (ePTZ) within the camera's predefined view area, if one has been defined.
	Auto Pan	This button starts the automatic panning function. The ROI will pan from back and forth within the FOV (field of view).
	Stop	This button stops the camera's ePTZ motion.
	Preset Path	This button starts the camera's motion along the predefined path.
	Video Profile 1	Click to select a predefined setting (profile). Refer to page 43 for configuration.
	Video Profile 2	Click to select an alternate predefined setting (profile). Refer to page 43 for configuration.
	Full Screen Mode	Click to enlarge the video stream to full-screen.
	Take a Snapshot	Click to record a snapshot of the current image.
	Record Video Clip	Click to record a video clip, using predefined settings.
	Set up Storage	Click to select a folder on your computer to save to.
	Listen/Stop Listening	Click to enable or disable the ability to listen through the built-in microphone.
	Talk/Stop Talking	Click to enable or disable the ability to speak through the built-in speaker.
	Start/Stop Digital Output	Click to enable or disable the ability to use the built-in digital in/out port.

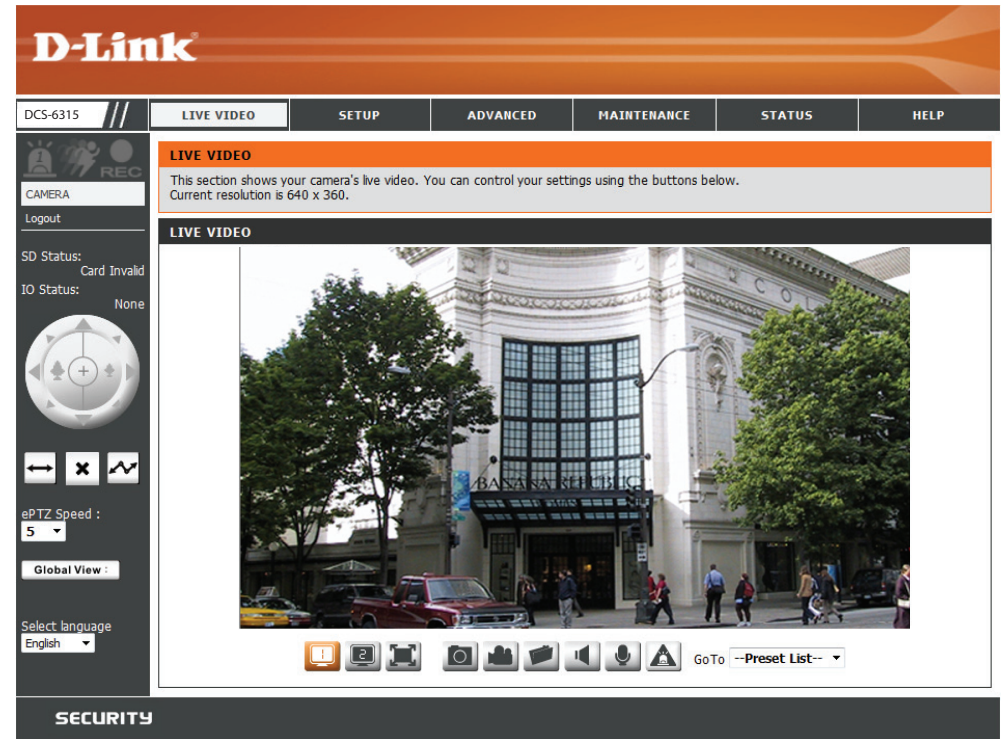

The screenshot displays the D-Link DCS-6315 web interface. At the top, the D-Link logo is visible. Below it, a navigation menu includes 'LIVE VIDEO', 'SETUP', 'ADVANCED', 'MAINTENANCE', 'STATUS', and 'HELP'. The 'LIVE VIDEO' section is active, showing a live video feed of a street scene with a large building and trees. To the left of the video feed is a control panel with a virtual control pad, buttons for 'Auto Pan', 'Stop', and 'Preset Path', and a 'Global View' button. Below the control pad, there are status indicators for 'SD Status: Card Invalid' and 'IO Status: None', an 'ePTZ Speed' dropdown set to '5', and a 'Select language' dropdown set to 'English'. At the bottom of the video feed, there are icons for 'Take a Snapshot', 'Record Video Clip', 'Set up Storage', 'Listen/Stop Listening', 'Talk/Stop Talking', and 'Start/Stop Digital Output', along with a 'Go To --Preset List--' dropdown. The word 'SECURITY' is displayed at the bottom of the interface.

Setup Setup Wizard

To configure your IP Camera, click **Internet Connection Setup Wizard**. To manually configure your camera, you may click **Manual Internet Connection Setup**, and skip to "[Network Setup](#)" on page 37.

To configure your IP Camera's motion detection settings, click **Motion Detection Setup Wizard**. If you want to enter your settings manually, click **Manual Motion Detection Setup**, and skip to "[Motion Detection](#)" on page 47.

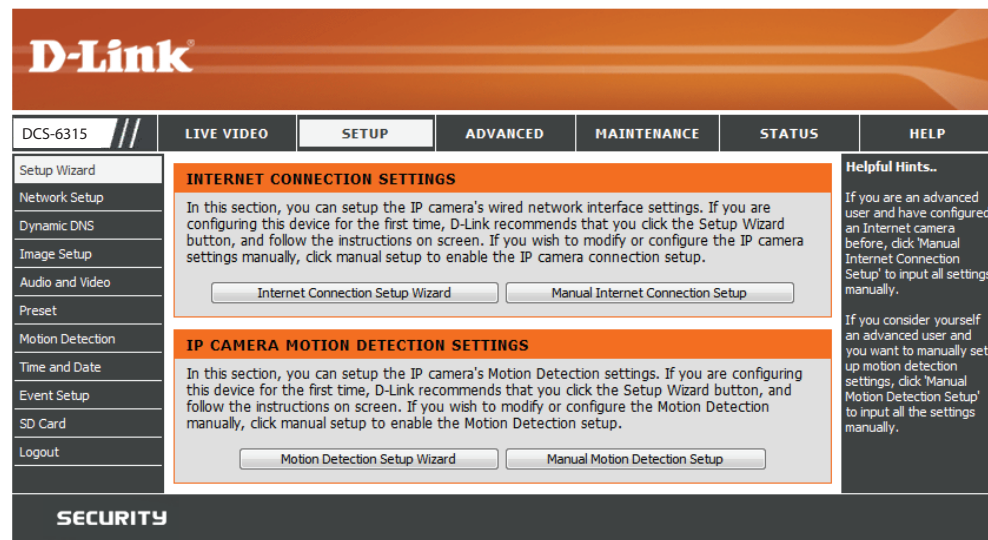

Internet Connection Setup Wizard

This *Setup Wizard* will guide you through a step-by-step process to configure your new D-Link camera and connect the camera to the Internet.

Click **Next** to continue.

Select **DHCP** (Dynamic IP) if you want your router or DHCP server to automatically assign the camera its network settings, or if you are unsure of which method to choose.

Select **Static IP Client** if you want to manually enter the network settings supplied by your Internet Service Provider (ISP), or if you wish to set a static IP address within your home network. Enter the correct configuration information and click **Next** to continue.

If you are using PPPoE, check the box to **Enable PPPoE** and enter your **User Name** and **Password**.

Click **Next** to continue.

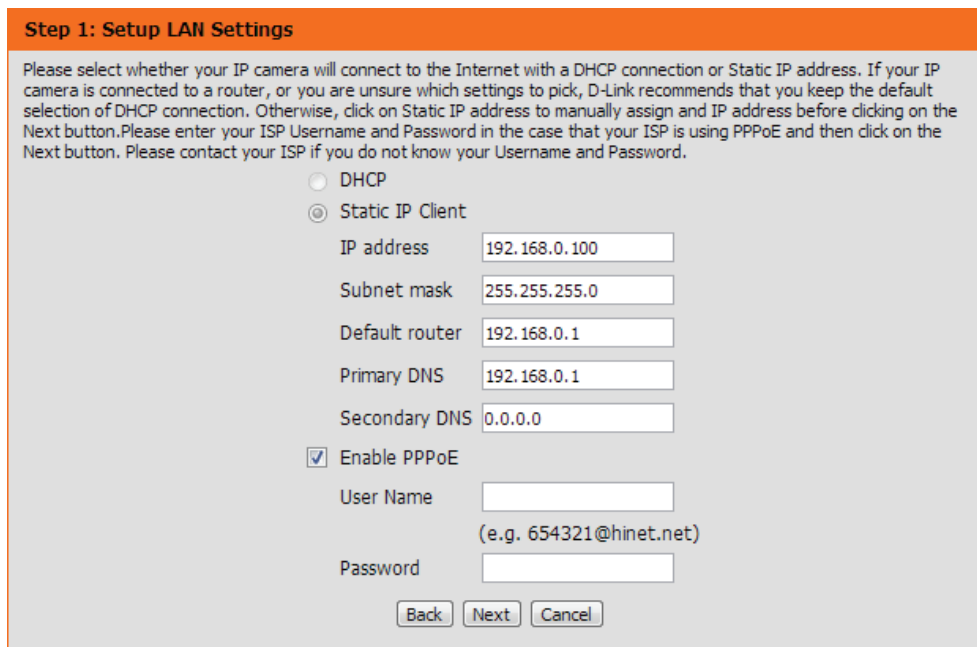
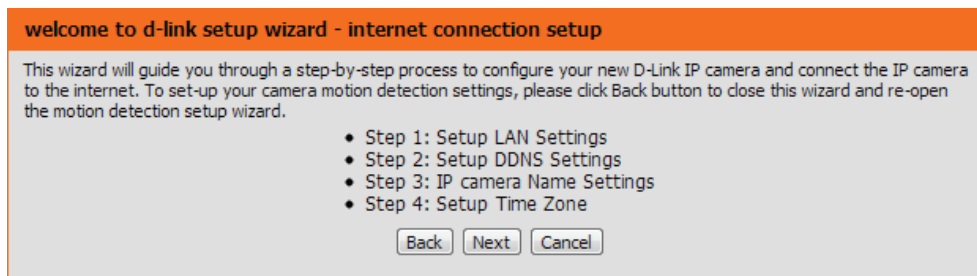

Section 3: Configuration

If you have a Dynamic DNS account and would like the IP camera to update your IP address automatically, check the box to **Enable DDNS**, and enter your host information.

Click **Next** to continue.

Step 2: Setup DDNS Settings

If you have a Dynamic DNS account and would like the IP camera to update your IP address automatically, enable DDNS and enter in your host information below. Please click on the Next button to continue.

Enable DDNS

Server Address << ▼

Host Name

User Name

Password

Verify Password

Timeout (hours)

Enter a name for your IP camera and click **Next** to continue.

Step 3: IP camera Name Settings

D-Link recommends that you rename your IP camera for easy accessibility. You can then identify and connect to your IP camera via this name. Please assign a name of your choice before clicking on the Next button.

IP camera Name

Section 3: Configuration

Select the applicable **Time Zone** to ensure that all events will be triggered as scheduled.

Click **Next** to continue.

Step 4: Setup Time Zone

Please configure the correct time to ensure that all events are triggered, captured and scheduled at the correct time and day and then click on the Next button.

Time Zone

Enable Daylight Saving

Confirm the IP camera settings are correct and click **Apply** to save your settings, or click **Back** to modify settings.

When you save your settings, the camera will restart.

Step 5: Setup complete

Below is a summary of your IP camera settings. Click on the Back button to review or modify settings or click on the Apply button if all settings are correct. It is recommended to note down these settings in order to access your IP camera on the network or via your web browser.

IP Address	DHCP
IP camera Name	DCS-6314
Time Zone	(UTC+08:00) Taipei
DDNS	Disable
PPPoE	Disable

Motion Detection Setup Wizard

This *Setup Wizard* will guide you through a step-by-step process to configure your IP camera's motion detection functions.

Click **Next** to continue.

Step 1

This step will allow you to enable or disable motion detection, and adjust the sensitivity of your camera's ability to detect movement.

Check the box by **Enable Video Motion** to enable motion detection. Click on the radio button to indicate if the camera should capture a **Snapshot** or a **Video Clip** whenever motion is detected.

Refer to "[Motion Detection](#)" on page 47 for details about how to configure motion detection.

Step 2

This step allows you to enable motion detection based on a customized schedule. Click on **Always** to make sure your camera always records whenever motion is detected. Or click on **From** and specify the day and hours you want motion detection enabled.

Click on **Next** to continue.

Welcome To D-LINK Setup Wizard - Motion Detection

This wizard will guide you through a step-by-step process to configure your IP camera's motion detection functions. To setup the IP camera LAN or Internet settings, please click on the Back button to close this wizard and re-open the IP camera Setup wizard. Otherwise click on the Next button to begin.

- Step 1: Specify Motion Detection Area Settings
- Step 2: Motion Detection Schedule
- Step 3: Alerts and Notifications

Back Next Cancel

Step 1: Specify Motion Detection Area Settings

This section will allow you to enable or disable motion detection as well as control the sensitivity of your camera's ability to detect movement.

Enable Video Motion Snapshot Video Clip



Sensitivity 85 0~100%

Percentage 5 0~100%

Back Next Cancel

step 2: Motion Detection Schedule

This final step allows you to specify how you receive notification of camera events. Choose between an email notification or alternatively you can setup an FTP Notification. You will need your email account settings or FTP details. If you are unsure of this information, please contact your ISP. Once you have entered this information, please click on the Next button.

Sun Mon Tue Wed Thu Fri Sat

Time

Always

From 00 To 23 59

Back Next Cancel

Step 3

This step allows you to specify how you would like to receive event notifications of events captured by your camera.

Choose **Do not notify me** if you do not want to receive notifications, or select a method for receiving notifications. If you select **E-mail** or **FTP**, enter required fields for your e-mail or FTP accounts.

Click **Next** to continue.

Step 3: Alerts and Notification

This final step allows you to specify how you receive notification of camera events. Choose between an email notification or alternatively you can setup an FTP Notification. You will need your email account settings or FTP details. If you are unsure of this information, please contact your ISP. Once you have entered this information, please click on the Next button.

Do not notify me

Email

Sender email address

Recipient email address

Server address

User name

Password

Port

FTP

Server address

Port

User name

Password

Remote folder name

Step 4

Your setup is complete. Confirm the IP camera settings are correct and click **Apply** to save your settings, or click **Back** to modify settings.

When you save your settings, the camera will restart.

Step 4: Setup Complete

You have completed your IP camera setup. Please click the Back button if you want to review or modify your settings or click on the Apply button to save and apply your settings.

Motion Detection : Enable

EVENT : Video Clip

Schedule Day : Sun , Mon , Tue , Wed , Thu , Fri , Sat ,

Schedule Time : Always

Alerts and Notification : Do not notify me

Network Setup

Use this section to configure the network connections for your camera. All relevant information must be entered accurately.

LAN Settings: This section lets you configure settings for your local area network (LAN).

DHCP: Select this connection if you have a DHCP server running on your network and would like your camera to obtain an IP address automatically.

Static IP Client: You may obtain a static or fixed IP address and other network information from your network administrator for your camera.

IP Address: Enter the fixed IP address in this field.

Subnet Mask: This number is used to determine if the destination is in the same subnet. The default value is 255.255.255.0.

Default Router: The gateway (router) used to forward frames to destinations in a different subnet. Invalid gateway settings may cause the failure of transmissions.

Primary DNS: The primary domain name server (DNS) that translates names into IP addresses.

Secondary DNS: The secondary DNS that acts as a backup to the primary server.

Enable UPnP Presentation: Enabling this setting allows your IP camera to be configured as a UPnP device on your network.

Enable UPnP Port Forwarding: Enabling this setting allows the camera to add port forwarding entries into the router automatically on a UPnP capable network.

D-Link

DCS-6315 // LIVE VIDEO SETUP ADVANCED MAINTENANCE STATUS HELP

Setup Wizard
 Network Setup
 Dynamic DNS
 Image Setup
 Audio and Video
 Preset
 Motion Detection
 Time and Date
 Event Setup
 SD Card
 Logout

NETWORK SETUP
 You can configure your LAN and Internet settings here.
 Save Settings Don't Save Settings

LAN SETTINGS

DHCP
 Static IP Client

IP address 192.168.1.101
 Subnet mask 255.255.255.0
 Default router 192.168.1.1
 Primary DNS 192.168.1.1
 Secondary DNS 0.0.0.0

Enable UPnP presentation
 Enable UPnP port forwarding

Forwarding Port 1024 Test
 Forwarding Status UPnP forwarding is inactive

PPPOE SETTINGS

Enable Disable

User Name
 Password
 Confirm password
 PPPoE Status PPPoE is inactive.

HTTP

HTTP port 80
 Access name for stream1 video1.mjpg
 Access name for stream2 video2.mjpg

HTTPS

HTTPS port 443

RTSP

Authentication Disable
 RTSP port 554
 Access name for stream1 live1.sdp
 Access name for stream2 live2.sdp

Helpful Hints..

Select DHCP Connection If you are running a DHCP server on your network and would like an IP address assigned to your IP camera automatically.

UPnP: Enabling UPnP settings will allow you to configure your IP camera as an UPnP device in the network.

PPPoE Setting: If you use the IP camera to connect directly to the Internet, you will need to enter the username and password, which were given to you when you set up your account with your Internet Service Provider. If the camera is behind a router or a gateway, you do not need to configure this setting.

HTTP: HTTP Port is the port you allocate in order to connect to the IP camera via a standard web browser.

HTTPS: HTTPS Port in a IP camera connects it with a PC via a secure web browser.

RTSP: RTSP Port is the port you allocate in order to connect to a IP camera by using streaming mobile device(s), such as a mobile phone or PDA.

CoS (Class of Service): Coarsely-grained traffic control based on the L2 protocol. Class of Service technologies do not guarantee a level of service in terms of bandwidth and delivery time, they offer a "best-effort".

QoS (Quality of Service): Finely-grained traffic control, a resource reservation control mechanism. Quality of service guarantees are important if the network capacity is insufficient.

Enable PPPoE: Click to **Enable** if your network uses PPPoE.

User Name/Password: Enter the **User Name** and **Password** for your PPPoE account. Re-enter your password in the **Confirm Password** field. You can obtain this information from your ISP.

HTTP Port: The default **HTTP Port** number is 80.

Access Name for Stream 1~2: The default name is video#.mjpg, where # is the number of the stream.

HTTPS Port: You may use a PC with a secure browser to connect to the **HTTPS Port** of the camera. The default port number is 443.

Authentication: You may choose to **Enable** or **Disable** RTSP (Real Time Streaming Protocol) digest encryption. Digest encryption uses MD5 hashes.

RTSP Port: The port number that you use for RTSP streaming to mobile devices, such as mobile phones or PDAs. The default port number is 554.

Access Name for Stream 1~2: You may specify the address of a particular stream. For instance, live1.sdp can be accessed at rtsp://x.x.x.x/video1.sdp where the x.x.x.x represents the ip address of your camera.

Enable CoS: Check the box to **Enable CoS** (Class of Service), for classification of network traffic. This setting implements a best-effort policy without making any bandwidth reservations. Select a number to specify traffic priority.

Enable QoS: Check the box to **Enable QoS** (Quality of Service), which establishes a reservation control mechanism for setting traffic priority. This will help improve performance during busy periods. Select a number to specify traffic priority. If the Network Camera is connected to a router that itself implements QoS, the router's settings will override the QoS settings of the camera.

PPPOE SETTINGS

Enable Disable
 User Name
 Password
 Confirm password
 PPPoE Status PPPoE is inactive.

HTTP

HTTP port
 Access name for stream1
 Access name for stream2

HTTPS

HTTPS port

RTSP

Authentication
 RTSP port
 Access name for stream1
 Access name for stream2

COS SETTINGS

Enable CoS
 VLAN ID [0~4095]
 Live video
 Live audio
 Event/Alarm
 Management

QOS SETTINGS

Enable QoS
 Live video
 Live audio
 Event/Alarm
 Management

Enable IPv6: If your network environment and equipment support IPv6, check the box and click **Save** to **Enable** IPv6 protocol.

IPv6 Information: Click the **IPv6 Information** button to obtain the IPv6 information. Or check the box to **Manually set up the IP address**. Then enter an **Optional IP address**, an **Optional default router**, and an **Optional primary DNS**.

Enable Multicast for stream: The DCS-6315 allows you to multicast each of the available streams via **Multicast group address** and specify the **TTL** (Time to Live) value for each stream. Enter the port and TTL settings you wish to use if you do not want to use the defaults.

Click **Save Settings** to save your changes.

QOS SETTINGS

Enable QoS

Live video	0	▼
Live audio	0	▼
Event/Alarm	0	▼
Management	0	▼

IPV6

Enable IPv6

Manually setup the IP address

Optional IP address / Prefix length	<input type="text"/>	/	<input type="text" value="64"/>
Optional default router	<input type="text"/>		
Optional primary DNS	<input type="text"/>		

MULTICAST

Enable multicast for stream 1

Multicast group address	<input type="text" value="239.1.1.1"/>
Multicast video port	<input type="text" value="6550"/>
Multicast RTCP video port	<input type="text" value="6551"/>
Multicast audio port	<input type="text" value="6552"/>
Multicast RTCP audio port	<input type="text" value="6553"/>
Multicast TTL [1~255]	<input type="text" value="64"/>

Enable multicast for stream 2

Multicast group address	<input type="text" value="239.1.1.2"/>
Multicast video port	<input type="text" value="6554"/>
Multicast RTCP video port	<input type="text" value="6555"/>
Multicast audio port	<input type="text" value="6556"/>
Multicast RTCP audio port	<input type="text" value="6557"/>
Multicast TTL [1~255]	<input type="text" value="64"/>

Dynamic DNS

DDNS (Dynamic Domain Name Server) will hold a DNS host name and synchronize the public IP address of the modem when it has been modified. A user name and password are required when using the DDNS service.

Enable DDNS: Check the box to **Enable** the DDNS function.

Server Address: Enter the **Server Address** manually or select your Dynamic DNS provider from the drop-down menu.

Host Name: Enter the **Host Name** of the DDNS server.

User Name: Enter the **User Name** or e-mail used to connect to your DDNS account.

Password: Enter the **Password** used to connect to your DDNS server account and verify your password.

Timeout: Enter the DNS **Timeout** value (in hours) that you wish to use.

Status: Displays the connection status, which is automatically determined by the system.

Click **Save Settings** to save your changes.

The screenshot shows the D-Link web interface for the DCS-6315 device. The top navigation bar includes 'LIVE VIDEO', 'SETUP', 'ADVANCED', 'MAINTENANCE', 'STATUS', and 'HELP'. The 'SETUP' menu is expanded to show 'Setup Wizard', 'Network Setup', 'Dynamic DNS', 'Image Setup', 'Audio and Video', 'Preset', 'Motion Detection', 'Time and Date', 'Event Setup', 'SD Card', and 'Logout'. The 'Dynamic DNS' page is active, displaying the following content:

DYNAMIC DNS

The Dynamic DNS feature allows you to use a domain name that you have purchased (www.yourdomain.com) to access your IP camera with a dynamically assigned IP address. Most broadband Internet service providers assign dynamic (changing) IP addresses. By using a DDNS service, you can enter your domain name to connect to your IP camera no matter what your IP address is.

[Sign up for D-Link's Free DDNS service at www.DLinkDDNS.com.](http://www.DLinkDDNS.com)

Buttons: Save Settings, Don't Save Settings

DYNAMIC DNS SETTING

Enable DDNS:

Server Address: <<

Host Name:

User Name:

Password:

Verify Password:

Timeout: (hours)

Status: Inactive

Buttons: Save Settings, Don't Save Settings

At the bottom of the page, the word 'SECURITY' is displayed.

Image Setup

In this section, you may configure the video image settings for your camera. A preview of the image will be shown under *Live Video*.

Enable Privacy Mask Setting: Check the box to **Enable Privacy Mask Setting**. This allows you to specify up to three rectangular areas on the image from the camera that you want hidden. These areas will be blocked or excluded from recordings and snapshots. You can click and drag the mouse cursor over the camera image to draw a mask area.

Right clicking on the camera image brings up the following menu options:

- **Disable All:** Disables all mask areas
- **Enable All:** Enables all mask areas
- **Reset All:** Clears all mask areas.

Mirror: Select **On** to mirror the image horizontally.

Flip: Select **On** to flip the image vertically. When you enable **Flip**, you may want to consider enabling **Mirror** on as well.

Power Line: Select the frequency used by your power lines to avoid interference or distortion.

White Balance: Use the drop-down menu to change **White Balance** settings to help balance colors for different environments. You can choose from **Auto**, **Outdoor**, **Indoor**, **Fluorescent**, and **Push Hold**.

The screenshot shows the D-Link web interface for the DCS-6315 camera. The main navigation bar includes 'LIVE VIDEO', 'SETUP', 'ADVANCED', 'MAINTENANCE', 'STATUS', and 'HELP'. The 'SETUP' menu is expanded, showing options like 'Setup Wizard', 'Network Setup', 'Dynamic DNS', 'Image Setup', 'Audio and Video', 'Preset', 'Motion Detection', 'Time and Date', 'Event Setup', 'SD Card', and 'Logout'. The 'Image Setup' page is active, displaying a live video feed of a street scene. Below the video, there are several settings:

- Enable Privacy Mask Setting:** A checkbox that is currently unchecked.
- Mirror:** Radio buttons for 'On' and 'Off' (selected).
- Flip:** Radio buttons for 'On' and 'Off' (selected).
- Power Line:** Radio buttons for '60 Hz' (selected) and '50 Hz'.
- White Balance:** A dropdown menu set to 'Auto'.
- Exposure Mode:** A dropdown menu set to 'Customize1', with a 'Max Gain' of 36 dB.
- Shutter:** Min: 1/30, Max: 1/30.
- Denoise:** A dropdown menu set to 0.
- Brightness:** A dropdown menu set to 128.
- Contrast:** A dropdown menu set to 128.
- Saturation:** A dropdown menu set to 128.
- Sharpness:** A dropdown menu set to 128.
- WDR Level:** A dropdown menu set to WDR, with a value of 5.

There is a 'Reset Default' button at the bottom of the settings section. On the right side of the interface, there is a 'Helpful Hints...' section with the following text:

Privacy Mask: Click the attached box to activate this function. Now use your mouse to draw a rectangle covering the area you want hidden. Click the box again to deactivate the function.

Mirror: This function horizontally reverses your images 180 degrees.

Flip: This function vertically reverses your images 180 degrees.

Power Line: This setting is used to remove 50/60 Hz flicker.

White Balance: White Balance - Is the process of removing unrealistic color casts, so that objects which appear white in person are rendered white in your photo.

Exposure Mode: Exposure is the total amount of light allowed to fall on the image sensor during the process of capturing an image. You may choose different scene modes to produce the better images.

Max Gain: It can always be enabled automatically. But you have an option - you can change Max Gain either automatically or manually.

Denoise: It is the process of removing noise from a signal.

Exposure Mode: Use the drop-down menu to change the **Exposure Mode**. Set the camera for **Indoor**, **Outdoor**, or **Night** environments. Select **Moving** to capture moving objects. The **Low Noise** option will create a high-quality picture without noise. You can also create three different custom exposure modes. The **Max Gain** setting will allow you to control the maximum amount of gain to apply to brighten the picture.

Shutter: Select a minimum and maximum value from the drop-down menu.

Denoise: This setting allows you to control the amount of noise reduction that will be applied to the picture. Select a value from the drop-down menu.

Brightness: Adjust this setting to compensate for backlit subjects.

Contrast: Adjust this setting to alter the color intensity/strength.

Saturation: This setting controls the amount of coloration, from grayscale to fully saturated.

Sharpness: Specify a value from zero to 128 to specify how much sharpening to apply to the image.

WDR Level: Specify a value from zero to 10 to specify how much WDR (Wide Dynamic Range) to apply to the image, or select None.

3D filter: Setting this option to **Low**, **Medium**, or **High** will help to reduce image artifacts, and result in images with less blur when viewing the camera during the night or in areas where there are low levels of light.

Reset Default: Click this button to reset the image to factory default settings.

The screenshot shows the D-Link DCS-6315 web interface. At the top, there's a navigation bar with 'LIVE VIDEO', 'SETUP', 'ADVANCED', 'MAINTENANCE', 'STATUS', and 'HELP'. The 'SETUP' tab is active, and the 'IMAGE SETUP' sub-tab is selected. Below the navigation, there's a 'Setup Wizard' section with a list of options: Network Setup, Dynamic DNS, Image Setup (selected), Audio and Video, Preset, Time and Date, Event Setup, SD Card, and Logout. The main content area is divided into two sections: 'LIVE VIDEO' and 'IMAGE SETTINGS'. The 'LIVE VIDEO' section shows a real-time camera feed of a street scene with a large building. The 'IMAGE SETTINGS' section contains various controls: Mirror (radio buttons for On/Off), Flip (radio buttons for On/Off), Power Line (radio buttons for 60 Hz/50 Hz), White Balance (dropdown menu set to Auto), Exposure Mode (dropdown menu set to Indoor), Max Gain (spinners set to 42 dB), Denoise (spinners set to 128), Brightness (spinners set to 4), Contrast (spinners set to 4), Saturation (spinners set to 128), Sharpness (spinners set to 4), WDR Level (dropdown menu set to WDR, spinners set to 5), and 3D filter (dropdown menu set to Low). A 'Reset Default' button is located at the bottom of the settings section. On the right side of the interface, there's a 'Helpful Hints...' section with several tips: Privacy Mask, Mirror, Flip, Power Line, White Balance, Exposure Mode, and Max Gain.

Audio and Video

You may configure up to three video profiles with different settings for your camera. This allows you to set up a profile for your computer that is different from your mobile display. You can also configure the two-way audio settings for your camera.

Number of Active Profiles: Select the number of profiles from the drop-down list. (Maximum is three.)

Aspect ratio: Set the aspect ratio of the video to **4:3** for standard or **16:9** for widescreen.

Mode: Set the video codec to be used to either **JPEG**, **MPEG-4**, or **H.264**.

Frame size / View window area: The **Frame size** is the total capture resolution. The **View window area** determines the live video viewing window size. The ePTZ function requires that the *frame size* is larger than the *view window area* in order to allow the user to pan, tilt, and zoom within the image area. In order to always be able to use the ePTZ on the *Live View* page, you should make sure you set the *frame size* larger than the *view window size* whenever you are setting video profiles.

16:9 1280 x 720, 800 x 450, 640 x 360, 480 x 270, 320 x 176 up to 30 fps

4:3 1024 x 768, 800 x 600, 640 x 480, 320 x 240 up to 30 fps

Note: If your *View window area* is the same as your *Frame size*, you will not be able to use the ePTZ function.

D-Link

DCS-6315 // LIVE VIDEO SETUP ADVANCED MAINTENANCE STATUS HELP

Setup Wizard
Network Setup
Dynamic DNS
Image Setup
Audio and Video
Preset
Motion Detection
Time and Date
Event Setup
SD Card
Logout

AUDIO AND VIDEO

This section allows you to configure the sound and video of your camera. You can configure different settings depending on whether you are viewing content from a PC or a Mobile Phone / PDA.

Save Settings Don't Save Settings

VIDEO SETTINGS

Number of active profiles 2
Aspect ratio 16:9
Warning: Change the aspect ratio will clear the settings of privacy mask and preset and motion detection.
Save Default

VIDEO PROFILE 1

Mode H.264
Frame size 640x360
View window area 640x360
Maximum frame rate 30
Video quality
Constant bit rate 2M
Fixed quality Excellent

VIDEO PROFILE 2

Mode JPEG
Frame size 640x360
View window area 640x360
Maximum frame rate 30
Video quality Excellent

AUDIO SETTINGS

Encoding G.711
Audio in gain level 20dB
Audio out volume level 10
Audio in off
Audio out off

Save Settings Don't Save Settings

Helpful Hints..

Higher frame size, frame rate and bit rate gives better video quality. At the same time, it requires more network bandwidth.

For best viewing results on a mobile phone, we suggest setting the Frame Rate to 5fps and the Bit Rate to 64 kbps.

Number of active profiles: Number of profiles that you wish to active. The maximum profiles are three.

Aspect Ratio: An aspect ratio is the ratio between the width and height of an image.

Mode: It can be H.264, JPEG, or MPEG-4. In JPEG mode, the video frames are independently. MPEG-4 consumes much less network bandwidth than JPEG, and H.264 can use less bandwidth but better image quality.

Frame Size: 7 options exist for the sizes of the video display. It is recommended using 176x144 for mobile viewing and 1920x1080 for computer viewing.

View window area: The viewing region of the current video stream.

Max frame rate: The maximum number of frames that is displayed in 1 second. 30fps is the highest video quality for this camera. In general, any frame rate above 15 fps is imperceptible to the human eye.

Video Quality: This limits the maximal refresh frame rate, which can be combined with the "Fixed quality" to optimize the bandwidth utilization and video quality. If the User

Maximum frame rate: Select a number that represents video frames per second. A higher frame rate means motion appears to be smoother, and requires more bandwidth. A lower frame rate will generally result in a stuttering motion, and requires less bandwidth.

Video Quality: Your selection limits the **Maximum frame rate**, which can be combined with the **Fixed quality** option to optimize the bandwidth utilization and **Video quality**. If fixed bandwidth utilization is your highest priority, regardless of video quality, you can choose **Constant bit rate** and select the desired bandwidth from the drop-down menu.

Constant bit rate: Select the number of bps (bits per second), which is the amount of data recorded by the camera at any given second. Recording at a higher bit rate results in higher video quality.

Fixed quality: Select the image quality level for the camera to maintain. High quality levels will result in increased bit rates.

Audio in off: Check the box to mute incoming audio.

Audio in gain level: This setting controls the amount of gain applied to incoming audio to increase its volume.

Audio out off: Check the box to mute outgoing audio.

Audio out volume level: This setting controls the amount of gain applied to outgoing audio to increase its volume.

Click **Save Settings** to save your changes.

VIDEO SETTINGS

Number of active profiles

Aspect ratio Warning: Change the aspect ratio will clear the settings of privacy mask and preset and motion detection.

VIDEO PROFILE 1

Mode

Frame size

View window area

Maximum frame rate

Video quality

Constant bit rate

Fixed quality

VIDEO PROFILE 2

Mode

Frame size

View window area

Maximum frame rate

Video quality

AUDIO SETTINGS

Encoding

Audio in off

Audio in gain level

Audio out off

Audio out volume level

Preset

This screen allows you to set *Preset* points for the ePTZ (Pan, Tilt, Zoom) function of your camera. Presets allow you to quickly go to and view a specific part of the viewing area your camera is covering. You can create *Preset Sequences*, which will automatically change the camera's view between the various presets according to a pre-defined order and speed.

Note: If your View window area is the same as your **Frame size**, you will not be able to use the ePTZ function.

Video Profile: Select a number from the drop-down menu that represents which **Video Profile** you would like to use for presets.

ePTZ Speed: You may select an **ePTZ Speed** value between zero and 10. Zero is the slowest and 10 is the fastest.

Arrow Buttons and Home Button: Use the **Arrow** buttons to move to a specific part of the viewing area, which you can then set as a **Button: Preset**. Click the **Home** button to return to the center of the viewing area.

Input Preset Name: Enter the name of the **Preset** you want to create, then click the **Add** button to make a new **Preset**. If an existing preset has been selected from the *Preset List*, you can change its name by typing in a new **Preset Name**, and clicking **Rename**.

Preset List: Click this drop-down menu to view a list of all the *Presets* that have been created. You can select one, then click the **GoTo** button to change the camera view to the **Preset** view. Clicking the **Remove** button will delete the currently selected **Preset**.

The screenshot displays the D-Link DCS-6315 camera web interface. The top navigation bar includes 'LIVE VIDEO', 'SETUP', 'ADVANCED', 'MAINTENANCE', 'STATUS', and 'HELP'. The 'SETUP' menu is expanded to show 'Setup Wizard', 'Network Setup', 'Dynamic DNS', 'Image Setup', 'Audio and Video', 'Preset', 'Motion Detection', 'Time and Date', 'Event Setup', 'SD Card', and 'Logout'. The 'Preset' option is selected.

The main content area is divided into three sections:

- PRESET CONTROL:** This section provides instructions: "Using the Pan and Tilt controls, move the camera view to the required position. There are provides the tools for creating and saving Preset positions & Preset Sequence." It features a live video feed of a building with a red dashed box indicating the current view. To the right of the video are controls for 'VIDEO PROFILE' (set to 2) and 'ePTZ Speed' (set to 5). Below these are five arrow buttons: Up, Down, Left, Right, and a Home button.
- PRESET:** This section allows for creating and managing individual presets. It includes an 'Input Preset Name' field with 'Add' and 'Rename' buttons. A note indicates 'Support(0~9,A~Z,a~z,-,*,/,_)'. Below is a 'Preset List' dropdown menu with a '--Preset List--' selection, and 'GoTo' and 'Remove' buttons.
- PRESET SEQUENCE:** This section is used to create automated sequences of camera movements. It shows a 'Preset Name' field with 'Dwell time' entered. To the right are Up, Down, and Home buttons. At the bottom, there is a 'Preset List' dropdown, an 'Add' button, a 'Dwell time' field with '10' entered, and 'Update' and 'Remove' buttons. A note indicates 'Second(s)[3~30]'.

On the right side of the interface, there is a 'Helpful Hints...' section with the following information:

- Input Preset Name:** Using the Pan, Tilt and Zoom (PTZ) controls, move the camera view to the required position and simply by selecting the preset's name.
- Add:** This camera position is then saved as a preset position in the camera.
- GoTo:** for test the preset the preset position.
- Preset Sequence:** A preset sequence is an automated series of camera movements from one preset position to another. A guard tour can be set up to display the video streams from different preset positions in a pre-determined order, and for configurable time periods.
- Add:** set up a new preset sequence, Modify to change, and Remove to remove an existing preset sequence.

Preset Sequence: This section allows you to create a *Preset Sequence*, which automatically moves the camera's view between a set of *Preset* views. To add a **Preset** to the sequence, select it from the *Preset List* drop-down menu, set the **Dwell time** to determine how long the camera view will stay at that *Preset*, then click **Add**. The *Preset Name* will appear in the list, followed by the specified *Dwell time*.

You can rearrange your **Presets** in the sequence by selecting a **Preset** in the sequence, and clicking the corresponding **Arrow** button to move it higher or lower in the current *Preset Sequence*.

Delete: Clicking the **Trash** icon will remove the currently selected preset from the sequence.

Update: If you want to change the **Dwell time** for a *Preset*, select it from the list, enter a new **Dwell time**, then click **Update**.

The screenshot displays two sections of the configuration interface:

- PRESET:** This section includes an "Input Preset Name" field, an "Add" button, and a "Rename" button. Below this is a "Preset List" dropdown menu showing "--Preset List--", a "GoTo" button, and a "Remove" button. A red note indicates "Support(0~9,A~Z,a~z,-,*,/,_)" for the preset names.
- PRESET SEQUENCE:** This section shows a "Preset Name : Dwell time" label above a large empty box. To the right of the box are three buttons: an up arrow, a trash can icon, and a down arrow. Below the box is a "Preset List" dropdown menu with "--Preset List--" and an "Add" button. At the bottom, there is a "Dwell time" input field containing the number "10", an "Update" button, and a red note "Second(s)[3~30]" indicating the valid range for the dwell time.

Motion Detection

Enable Video Motion to allow your camera to use the motion detection feature. You may define a specific area that the camera will use for monitoring.

Enable Video Motion: Check the box to **Enable** the motion detection feature of your camera.

Sensitivity: Specifies the measurable difference between two sequential images that indicates motion. Enter a value between zero and 100.

Percentage: Specifies the amount of motion in the window being monitored that is required to initiate an alert. If this is set to 100%, any motion detected within the entire window triggers an alert.

Draw Motion Area: Draw the motion detection area by dragging your mouse within the window (indicated by a red square).

Erase Motion Area: To erase a motion detection area, simply click on the red square that you wish to remove.

Right clicking on the camera image brings up the following menu options:

Select All: Draws a motion detection area over the entire screen.

Clear All: Clears any motion detection areas that have been drawn.

Restore: Restores the previously specified motion detection areas.

Click **Save Settings** to save your changes.

Time and Date

This section allows you to automatically or manually configure, update, and maintain the internal system clock for your camera.

Time Zone: Select your **Time Zone** from the drop-down menu.

Enable Daylight Saving: Check the box to **Enable Daylight Saving Time**.

Auto Daylight Saving: Click **Auto Daylight Saving** to allow your camera's clock to automatically adjust according to the *Daylight Saving Time* of the selected *Time Zone*.

Set Date and Time Manually: Click **Set date and time manually** to set the *Daylight Saving Date and Time* manually.

Offset: Select the amount of time to be added or removed when *Daylight Saving* is enabled.

Start Time: Select *Daylight Saving Start Time*.

End Time: Select *Daylight Saving End Time*.

Synchronize with NTP Server: Check the box to obtain the time automatically from an NTP (Network Time Protocol) server.

NTP Server: Select the NTP server that is closest to your location.

Set the Date and Time Manually: Click this option to set the **Time** and **Date** for the internal system clock manually.

Copy Your Computer's Time Settings: Click to synchronize the **Time** and **Date** from your PC.

Click **Save Settings** to save your changes.

The screenshot shows the D-Link DCS-6315 web interface. The top navigation bar includes 'LIVE VIDEO', 'SETUP', 'ADVANCED', 'MAINTENANCE', 'STATUS', and 'HELP'. The 'SETUP' menu is expanded to show 'Time and Date'. The main content area is titled 'TIME AND DATE' and contains the following sections:

- TIME AND DATE:** A message box stating 'You can set the current time for the IP camera.' with 'Save Settings' and 'Don't Save Settings' buttons.
- TIME CONFIGURATION:**
 - Time Zone: (UTC+08:00) Taipei
 - Enable Daylight Saving
 - Auto Daylight Saving
 - Set date and time manually
 - Offset: +2:00
 - Start time: 5:00 Sunday
 - End time: 10:00 Sunday
- AUTOMATIC TIME CONFIGURATION:**
 - Synchronize with NTP Server
 - NTP Server: ntp.dlink.com.tw
- SET DATE AND TIME MANUALLY:**
 - Set date and time manually
 - Year: 2013, Month: 1, Day: 21
 - Hour: 3, Minute: 45, Second: 22
 - Copy Your Computer's Time Settings button

On the right side, there is a 'Helpful Hints..' section with text explaining the importance of timekeeping, the function of the Time Zone dropdown, the effect of enabling Daylight Saving, the function of Auto Daylight Saving, the function of the Offset field, and the function of the Synchronize with NTP Server checkbox. At the bottom right, there is a 'Copy Your Computer's Time' button.

Event Setup

Typically, when motion is detected, the DCS-6315 sends images to a FTP server or sends e-mail notifications. As shown in the illustration below, an event can be triggered by various conditions, such as motion detection or system reboot. When an event is triggered, a specified action will be performed. You can configure the Network Camera to send snapshots or videos to your e-mail address or FTP site.

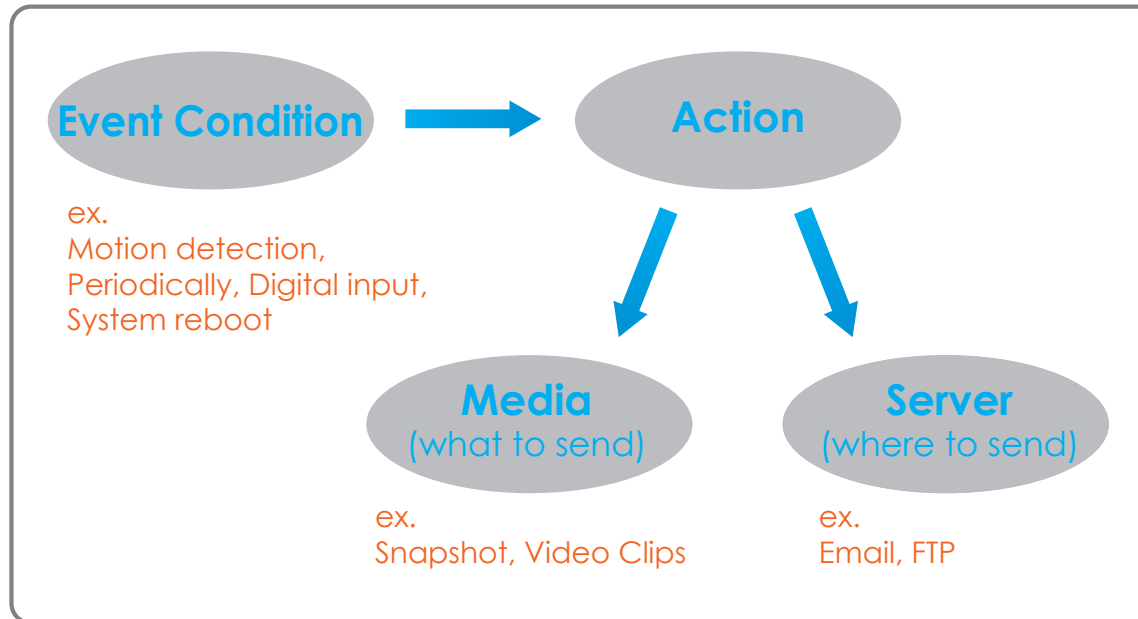

Instructions for setting an Event begin on the next page. Proper setup enables your DCS-6315 to perform as expected when a trigger is activated.

The Event Setup page includes four different sections.

- Server
- Media
- Event
- Recording

1. To add a new item select a **Server, Media, or Event** and click **Add**. A screen will open allowing you to update fields and add the item.
2. To remove a selected item from the drop-down menu, click **Delete**.
3. Click on the item name from the drop-down menu to open up a window for modifying the item.

The pages that follow provide instructions on how to *Add a Server, Add Media, Add Event, and Add Recording*.

D-Link

DCS-6315 // LIVE VIDEO SETUP ADVANCED MAINTENANCE STATUS HELP

Setup Wizard
Network Setup
Dynamic DNS
Image Setup
Audio and Video
Preset
Motion Detection
Time and Date
Event Setup
SD Card
Logout

EVENT SETUP

There are four sections in Event Setup page. They are event, server, media and recording. Click Add to pop a window to add a new item of event, server, media or recording. Click Delete to delete the selected item from event, server, media or recording. Click on the item name to pop a window to edit it. There can be at most 3 events and 2 recording. There can be at most 5 server and 5 media configurations.

SERVER

Name	Type	Address/Location
Add	▼	Delete

MEDIA

Name	Type	Source
Add	▼	Delete

EVENT

Name	Status	Sun	Mon	Tue	Wed	Thu	Fri	Sat	Time	Trigger
Add	▼									Delete

RECORDING

Name	Status	Sun	Mon	Tue	Wed	Thu	Fri	Sat	Time	Source	Destination
Add	▼										Delete

Helpful Hints..
Suggest setting server and media first before setting event. The servers and media which selected in event list are not be able to modify or delete. Please remove them first from the event if you want to delete or modify them. Recommend using different media in different event to make use all media be produced and received correctly. If using the same media in different events and the events trigger almost simultaneously, the servers in the second triggered event will not receive any media; there would be only notifications.

SECURITY

Add a Server

You can configure up to five servers for saving snapshots and videos to. Select a server type, **Email**, **FTP**, or **Network Storage**, and fill-in the corresponding fields below. Or simply select **SD Card**.

Server Name: Enter the unique name of your server.

Email: Click **Email** and enter the configuration for the target e-mail server account.

FTP: Click **FTP** and enter the configuration for the target FTP server account.

Network Storage: Click **Network storage** and specify a **Network Storage: storage location** for uploading the media. Only one network storage device is supported.

SD Card: Select **SD Card** to use the camera's onboard SD card storage.

Click **Save Settings**.

D-Link

DCS-6315 // LIVE VIDEO SETUP ADVANCED MAINTENANCE STATUS HELP

Setup Wizard
Network Setup
Dynamic DNS
Image Setup
Audio and Video
Preset
Motion Detection
Time and Date
Event Setup
SD Card
Logout

SERVER

You can set at most 5 different servers here for different event.

Test Save Settings Don't Save Settings

SERVER TYPE

Server Name:

Email

Sender email address

Recipient email address

Server address

User name

Password

Port

This server requires a secure connection (StartTLS)

FTP

Server address

Port

User name

Password

Remote folder name

Passive mode

Network storage

Network storage location
(for example: \\my_nas\disk\folder)

Workgroup

User name

Password

Primary WINS server

SD Card

Test Save Settings Don't Save Settings

Helpful Hints..

"Server name" The unique name for server. There are four kinds of servers supported. They are email server, FTP server, HTTP server and network storage.

Email server: "Sender email address" The email address of the sender. "Recipient email address" The email address of the recipient.

FTP server: "Remote folder name" Granted folder on the external FTP server. The string must conform to that of the external FTP server. Some FTP servers cannot accept preceding slash symbol before the path without virtual path mapping. Refer to the instructions for the external FTP server for details. The folder privilege must be open for upload. "Passive Mode" Check it to enable passive mode in transmission.

Network storage: Only one network storage is supported. "Network storage location" The path to upload the media. "Workgroup" The workgroup for network storage.

SD card: Use the SD card for recording media.

Add Media

You can configure up to five instances of *Media* using the three types, **Snapshot**, **Video Clip**, and **System log**.

Media Name: Enter a unique name for *Media Type* you want to create.

Snapshot: Click to set *Media Type* to **Snapshot**.

Source: Select a **Video Profile** to use as the media source. Refer to "Audio and Video" on page 43 for more information.

Send pre-event image(s) [0~4]: Select the number of **pre-event images** to send. *Pre-event images* are images taken before the main event snapshot is taken. You can set up to four *pre-event images*.

Send post-event image(s) [0~7]: Select the number of **post-event images** to send. *Post-event images* are images taken after the main event snapshot is taken. You can set up to seven post-event images to be taken.

File name prefix: Enter the prefix name to be added onto the file name.

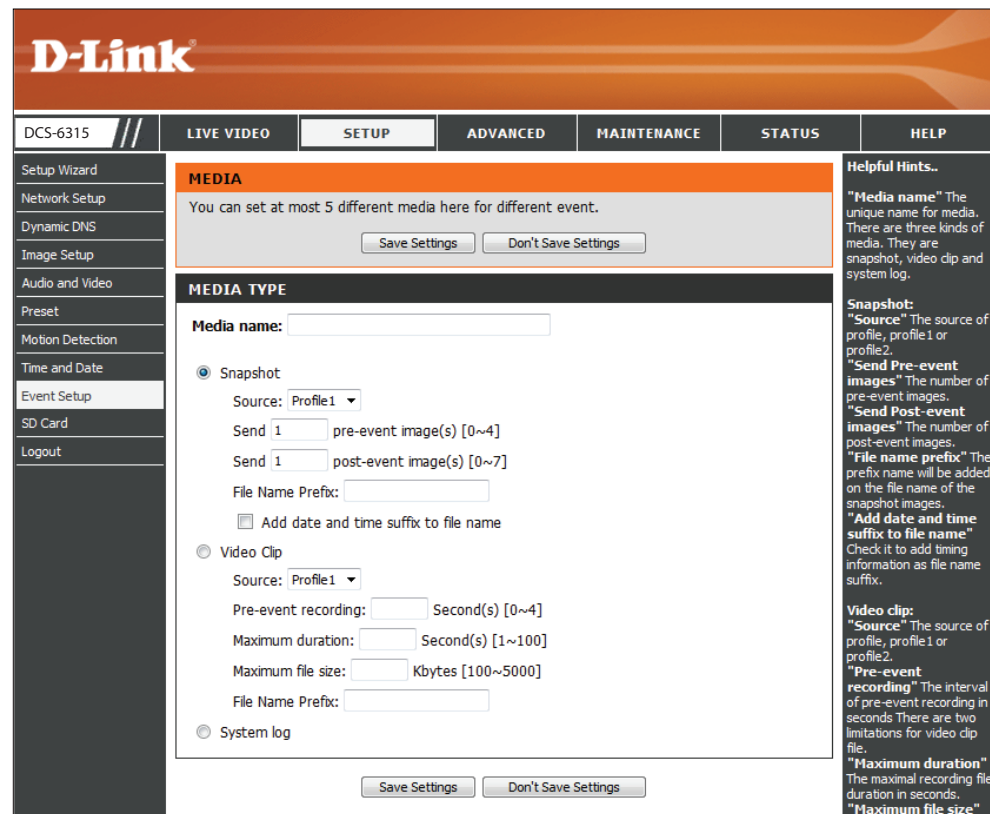
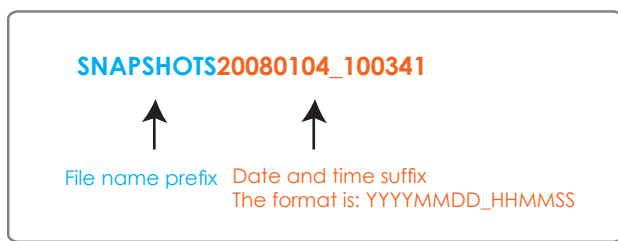

Add date and time suffix to file name: Check this box to **Add date and time** as file name suffix. Refer to the previous page for an example of how the file name will be displayed when this option is enabled.

Video Clip: Click to set the *Media Type* to **Video Clip**.

Source: Select a **Video Profile** to use as the *Media Source*. Refer to "Audio and Video" on page 43 for more information.

Pre-event recording: Select the number of seconds to record before the main event video clip starts. You can record up to four seconds of pre-event video.

Maximum duration: Set the maximum length of time (in seconds) to record video for your video clips.

Maximum file size: Set the maximum file size (in Kbytes) to record for video for your video clips.

File Name Prefix: Enter the prefix name to be added onto the file name.

System log: Click to set the *Media Type* to **System log**. This will save the event to the camera's *System log*, but no snapshots or video will be recorded.

Click **Save Settings**.

MEDIA TYPE

Media name:

Snapshot

Source: Profile1 ▾

Send pre-event image(s) [0~4]

Send post-event image(s) [0~7]

File Name Prefix:

Add date and time suffix to file name

Video Clip

Source: Profile1 ▾

Pre-event recording: Second(s) [0~4]

Maximum duration: Second(s) [1~100]

Maximum file size: Kbytes [100~5000]

File Name Prefix:

System log

Add Event

You can create and schedule up to three *Events*.

Event name: Enter a **Name** for the *Event*.

Enable this event: Check the box to **Enable this event**.

Priority: Select the **Priority** level for this *Event*. The one with the higher priority will be executed first.

Delay: Enter the **Delay** (time in seconds) before checking for the next event. The delay time is used for both motion detection and digital input triggers.

Video Motion Detection: Click to set the *Trigger* to **Video motion** detected during live video monitoring.

Periodic: Click to trigger an *Event* at specified intervals, and enter a value in minutes.

Digital Input: Click to trigger an *Event* when DI status changes.

System Boot: Click to trigger an *Event* when the system boots up.

Network Lost: Click to trigger an *Event* whenever the network connection is lost.

Time: Select days of the week the Event should be performed or click **Always** for every day, or click **From** and specify a time range.

Trigger D/O: Check the box to trigger Digital Output for a specified number of seconds and enter a value.

Click **Save Settings**.

Add Recording

You can set up a schedule for recording video to network storage.

Recording entry name: Enter a unique **Name** for the Recording.

Enable this recording: Check the box to **Enable** the recording function if you would like to upload the recording to a shared folder on the network.

Priority: Set the **Priority** for this entry. The entry with a higher priority value will be executed first.

Source: Select the **Profile** to use as the *Source* of the stream.

Time: Select days of the week the video should be recorded or click **Always** if you would like the IP camera to record video clips continuously. Click **From** if you want to specify a time range.

Destination: Select the folder where you want the recording file to be stored.

Total cycling recording size: Enter a storage size between 1MB and 2TB for video recordings. The new recordings will replace the oldest when the total recording size exceeds this value. For example, if each recording file is 6MB, and the total cyclical recording size is 600MB, then the camera will record 100 files in the specified location (folder) and then will delete the oldest file and create new file for cyclical recording.

D-Link

DCS-6315 // LIVE VIDEO SETUP ADVANCED MAINTENANCE STATUS HELP

RECORDING

You can setup schedule recording to network storage with your specify week day and time period.

Save Settings Don't Save Settings

RECORDING

Recording entry name:

Enable this recording

Priority: normal

Source: Profile 1

RECORDING SCHEDULE

Sun Mon Tue Wed Thu Fri Sat

Time

Always

From 00:00 To 23:59

RECORDING SETTINGS

Destination: None

Total cycling recording size: 1000 Mbytes [200~2000000]

Size of each file for recording: 10 Mbytes

Time of each file for recording: 10 seconds

File Name Prefix:

Save Settings Don't Save Settings

Helpful Hints..

Recording: Enable this option if you want to upload the recording to a shared folder on the network.

Recording schedule: Select the day(s) according to when you want the IP camera to make a video clip.

Always: This enables the IP camera to make video clips continuously.

From: The time range specified for the video clip.

Total cycling recording size: Please input the network path of your network storage, it will like "\\DNS\IPCamRecord\". If the network storage need authentication, please enter your user name and password here.

Note: Please Format SD card before use. The entire data in the SD card will be erased after formatting.

Size of each file for recording: Click **Size of each file for recording** if you want the file size to be based on the number of megabytes you specify.

Time of each file for recording: Click **Time of each file for recording** if you want the length of the video clip to be based on the maximum length of time (in seconds) that you specify.

File Name Prefix: Enter the prefix name to be added onto the file name of the recording file(s).

Click **Save Settings**.

RECORDING SCHEDULE

Sun Mon Tue Wed Thu Fri Sat

Time

Always

From To

RECORDING SETTINGS

Destination

Total cycling recording size: Mbytes [200~2000000]

Size of each file for recording: Mbytes

Time of each file for recording: seconds

File Name Prefix:

SD Card

You can manage the video files that are stored on the SD card. Organize and view pictures and recorded video.

Files per Page: Select a number of files to view at once from the drop-down menu.

Refresh: Click on the **Refresh** link to reload the file and folder information from the SD card.

Delete: Check the box by the link(s) to the file(s) you would like to remove and click **OK**.

Format SD Card: Click this button to automatically format the SD card and create *Picture* and *Video* folders.

View Recorded Picture: If the picture files are stored on the SD card, click on the **Picture** link and choose the file(s) you would like to view.

Playback Recorded Video: If video files are stored on the SD card, click on the **Video** link and choose the file(s) you would like to view.

The screenshot shows the D-Link web interface for the DCS-6315 camera. The main content area is titled "SD CARD" and contains the following information:

SD Card: / SD Status: Ready

Files per Page: 10 Refresh 1 of 1

<input type="checkbox"/>	Delete	File	Num of files	Size
<input type="checkbox"/>		dcm	0	
<input type="checkbox"/>		Video	0	
<input type="checkbox"/>		Picture	0	
<input type="checkbox"/>		2011_06_22_HALF at Lights out Day	1	
<input type="checkbox"/>		nikon001.dsc		1

Format SD Card Total:15981056KB, Used:7878368KB, Free:8102688KB

OK

Helpful Hints..

Format SD Card: Click this icon, system will automatically format SD card and create "picture" & "video" folders.

View recorded picture: If SD stored recorded picture files, enter picture link and choose which picture file you desire to view. You will view picture via image viewer SW. (ie. Windows Image Viewer)

Playback recorded video: If SD stored recorded video files, enter video link and choose which video file you desire to playback. Windows will guide you to open/download video file

Advanced Digital Input/Output

This screen allows you to control the behavior of digital input (DI) and digital output (DO) devices. The I/O connector provides the physical interface for DO and DI that is used for connecting a variety of external alarm devices, like IR-Sensors and alarm relays. Once the alarm is triggered, images are recorded and sent by e-mail.

D/I or D/O Active State: The camera will send a signal when an event is triggered, depending upon the type of device connected and the **Active State** selected.

N.C. stands for *Normally Closed*. Select this option when the normal state of the circuit is closed. Therefore events are triggered when the device status changes to *Open*.

N.O. stands for *Normally Open*. Select this option when the normal state of the circuit is open. Therefore events are triggered when the device status changes to *Closed*.

Click **Save Settings**.

The screenshot shows the D-Link web interface for the DCS-6315 camera. The top navigation bar includes 'LIVE VIDEO', 'SETUP', 'ADVANCED', 'MAINTENANCE', 'STATUS', and 'HELP'. The 'ADVANCED' tab is selected, and the 'DI AND DO' sub-tab is active. The main content area is divided into two sections for 'DI AND DO' configuration. The first section provides a general description of the I/O connector and includes a 'Save Settings' button. The second section shows the configuration for 'Digital Input 1' and 'Digital Output', both with 'N.O.' selected in the 'Active state' dropdown menu. A 'Helpful Hints...' sidebar on the right provides additional information about the I/O terminal block and pin connections.

ICR and IR

You can configure the ICR (*Removable IR-Cut Filter*) and IR (*Infrared Light Control*) settings. When the ICR filter is switched on, it blocks infrared light and allows only visible light to pass through. The ICR filter is disengaged for increased sensitivity in low-light environments.

Automatic: Click **Automatic** if you want the *Day/Night mode* to be set automatically. Generally, the camera will use *Day mode* and switch to *Night mode* when it gets dark.

Day Mode: Click **Day mode** to enable the IR Cut Filter.

Night Mode: Click **Night mode** to disable the IR Cut Filter.

Schedule Mode: Click **Schedule mode** to set up the *Day/Night mode* using a schedule. Select a starting time for the camera to enter *Day mode*, and an ending time for the camera to change to *Night mode*.

IR Light Control: The camera can enable or disable the IR (infrared) light control according to the light conditions. Click on **Automatic** and make a selection from the drop-down menu.

Off: Click **Off** so the IR light control is always disabled.

On: Click **On** so the IR light control is always enabled.

Sync with ICR: The IR light will turn on when the ICR sensor is on.

Schedule: Click **Schedule** so the IR light control will turn on or off according to the schedule that you specify.

Click **Save Settings**.

The screenshot shows the D-Link DCS-6315 web interface. The top navigation bar includes 'LIVE VIDEO', 'SETUP', 'ADVANCED', 'MAINTENANCE', 'STATUS', and 'HELP'. The 'ADVANCED' tab is selected, and the 'ICR AND IR' settings page is displayed. The page is divided into three main sections: 'ICR AND IR', 'ICR', and 'IR LIGHT'. On the right side, there is a 'Helpful Hints...' sidebar with additional information.

ICR AND IR

An IR(Infrared) Cut-Removable(ICR) filter can be disengaged from the image path for increased sensitivity in low light environments. The ICR filter will automatically engage depending on the ambient light, allowing the camera to be effective in day/night environments.

- Select the Day/Night from the radio button. The available options are Automatic, Schedule mode, Day mode and Night mode.
- The default value is Automatic.

Light Sensor Sensitivity
Light sensor sensitivity has Low, Medium, and High three different levels. You may get current camera light illumination by clicking Refresh button to set proper level of Light sensor sensitivity. For example, when level sets at High less than 30lux. camera will switch Day & Night mode to Night mode.

IR Light
The built-in IR light illuminators will be activated automatically or manually so as to supplement the low light situation without additional equipment.

Buttons: Save Settings, Don't Save Settings

ICR

Removable IR-Cut filter trigger condition:

- Automatic Sensitivity: Medium: <20lux over 30 lux Refresh
- Day mode
- Night mode
- Schedule mode

Day mode(24hr)
From 07 To 18

IR LIGHT

IR Light Control: Medium

- Off
- On
- Sync. With ICR
- Schedule

IR Light Control On(24hr)
From 07 To 18

Buttons: Save Settings, Don't Save Settings

Helpful Hints...

ICR and IR:
Automatic: The day/Night mode is set automatically. It is normally set in the Day mode and changes to the Night mode in a dark place.
Day mode: The Day mode means disable the IR Cut Filter.
Night mode: The Night mode means enable the IR Cut Filter.
Schedule mode: Set the Day/Night mode using the schedule. Fill in the time so the Day/Night mode is normally set to Day mode and it enters the Day mode at the start time and returns to the Night mode at the end time.
IR Light Control: In poor light conditions, open IR Light Control to automatically turn on the light to enable you to take clear picture. The IR Light Control has 4 options: Off, On, Sync. with ICR, and Schedule. Off: This option disable the IR Light Control. On: This option automatically opens the IR Light Control to enable a camera to take clear images in poor light conditions. Sync. with ICR: In this option, the IR Light Control will open automatically and follow the ICR setting. Schedule: In this option, you have to customize the setting to set the time period you want. Please set the Start time and the End time of your chosen schedule.

HTTPS

You can create and activate an HTTPS (Hypertext Transfer Protocol Secure) certificate for secure access to your camera.

Enable HTTPS Secure Connection: Check the box to **Enable** the HTTPS service, for secure communication over computer networks.

Create Certificate Method: Choose the way the certificate should be created.

Method: Select one of the three methods:

- **Create a self-signed certificate automatically**
- **Create a self-signed certificate manually**
- **Create a certificate request and install**

Create: Click to **Create** certificate.

Certificate Information: Displays the certificate *Status*, location of origin, and the *Organization* responsible for creation of the certificate.

Click **Save Settings**.

Note: The certificate cannot be removed while the HTTPS is still enabled. To remove the certificate, you must first uncheck **Enable HTTPS secure connection**.

The screenshot shows the D-Link web interface for the DCS-6315 camera. The main navigation bar includes 'LIVE VIDEO', 'SETUP', 'ADVANCED', 'MAINTENANCE', 'STATUS', and 'HELP'. The 'ADVANCED' tab is selected, and the 'HTTPS' sub-tab is active. The page content is as follows:

- HTTPS** (Section Header)
- To enable HTTPS, you have to create and install certificate first.
 - Buttons: [Save Settings](#), [Don't Save Settings](#)
- HTTPS** (Section Header)
- Enable HTTPS secure connection
- Create certificate method
 - Create self-signed certificate automatically
 - Create self-signed certificate manually
 - Create certificate request and install
- Create certificate: [Create](#) Private key existed
- CERTIFICATE INFORMATION** (Section Header)
- Table:

Status	Active
Country	TW
State or province	Taiwan
Locality	Taipei
Organization	D-Link Taiwan
Organization Unit	R&D Dept.
Common Name	www.dlink.com.tw
- Buttons: [CSR Property](#), [Certificate Property](#), [Remove](#)
- Buttons: [Save Settings](#), [Don't Save Settings](#)

Helpful Hints...

Enable HTTPS secure connection: allows you to enable HTTPS service.

Note:

1. The certificate can't be removed while the HTTPS is still enable. To remove the certificate you have to uncheck the "Enable HTTPS secure connection" first.

Access List

Here you can set permissions to access video from your IP camera.

Allow List/Start IP address: The starting *IP Address* of the device(s), like a computer, that has access to the video from the camera. Click **Add** to save.

End IP address: The ending *IP Address* of the device(s) that has access to the video from the camera. Click **Add** to save.

Note: A total of seven lists can be configured for each column.

Delete: Remove the **IP Address** from the *Allow List*.

Deny list/Start IP address: The starting *IP Address* of the device(s), like a computer, that DOES NOT have access to the video from the camera. Click **Add** to save.

End IP address: The ending *IP Address* of the device(s), like a computer, that DOES NOT have access to the video from the camera. Click **Add** to save.

Delete: Remove the **IP Address** from the *Deny List*.

For example:

When the range of the *Allow List* is set from 1.1.1.0 to 192.255.255.255 and the range of the *Deny List* is set from 1.1.1.0 to 170.255.255.255. Only users with IPs located between 171.0.0.0 and 192.255.255.255 can access the Network Camera.

The screenshot shows the D-Link DCS-6315 web interface. The top navigation bar includes 'LIVE VIDEO', 'SETUP', 'ADVANCED', 'MAINTENANCE', 'STATUS', and 'HELP'. The 'ADVANCED' tab is selected, leading to the 'ACCESS LIST' configuration page. The page title is 'ACCESS LIST' and it contains the instruction: 'Here you can set access permissions for users to view your IP camera.' Below this, there are two sections: 'ALLOW LIST' and 'DENY LIST'. Each section has input fields for 'Start IP address', 'End IP address', and a 'Delete' button. The 'ALLOW LIST' section also has a 'Delete allow list' dropdown menu. A 'Helpful Hints...' sidebar on the right provides additional information about the 'Allow List' and 'Deny List' settings.

Maintenance

Device Management

Here you may change settings for the administration of the camera. You can add or delete user accounts, as well as enable or disable certain functions like the on-screen display (OSD) or camera LEDs.

Admin/New Password: Enter a **New Password** for the administrator's account, retype to verify password, and click **Save**.

User Name: Enter a **User Name** for a new *User Account*.

User/New Password: Enter a **New Password** for the new *User Account*, retype to verify password, and click **Add**.

User List: All the existing user accounts will be displayed in the *User List*. Select a user and click on **Delete** to remove an account from the list. You may want to reserve at least one as a guest account.

IP Camera Name: Create a unique name for your camera that will be added to the file name prefix when creating a snapshot or a video clip.

Enable OSD: Check the box to **Enable OSD** (On-Screen Display) feature for your camera.

Label: Enter a **Label** for the camera, which will be shown on the OSD when it is enabled.

Show Time: Check the box to enable the time-stamp display on the video screen. Or, leave unchecked and click **Save** to save device settings.

LED: Click **On** to turn the camera LED on, or click **Off**. Then click **Save** to save the LED setting.

The screenshot displays the D-Link web interface for the DCS-6315 camera. The top navigation bar includes 'LIVE VIDEO', 'SETUP', 'ADVANCED', 'MAINTENANCE' (selected), 'STATUS', and 'HELP'. The left sidebar shows 'Admin', 'System', 'Firmware Upgrade', and 'Logout'. The main content area is titled 'ADMIN' and contains several sections:

- ADMIN:** A text box explaining that users can change the administrator's password, add/delete user accounts, and configure OSD information.
- ADMIN PASSWORD SETTING:** Fields for 'New Password' (63 characters maximum) and 'Retype Password', with a 'Save' button.
- ADD USER ACCOUNT:** Fields for 'User Name' (20 users maximum), 'New Password' (63 characters maximum), and 'Retype Password', with an 'Add' button.
- USER LIST:** A dropdown menu for 'User Name' and a 'Delete' button.
- DEVICE SETTING:** Fields for 'IP camera Name' (63 characters maximum), 'Label' (30 characters maximum), and a 'Show time' checkbox. A 'Save' button is at the bottom.
- LED:** Radio buttons for 'On' (selected) and 'Off', with a 'Save' button.

On the right side, there is a 'Helpful Hints...' section with two paragraphs: one about enabling OSD and another about the camera's LED indicator.

System

In this section, you may backup, restore and reboot your camera.

Save To Local Hard Drive: Click **Save Configuration** to save your current camera configuration as a file on your computer.

Load From Local Hard Drive: Click **Choose File** to locate a pre-existing configuration on your local hard drive. Restore the pre-defined settings to your camera by clicking **Load Configuration**.

Restore to Factory Default: Click **Restore Factory Defaults** to reset your camera and restore the factory default settings.

Note: If you reset to factory default settings, you can use the Camera Installation Wizard to reconfigure your DCS-6315. Refer to "[Software Installation](#)" on page 25.

Reboot Device: Click **Reboot Device** to restart your camera.

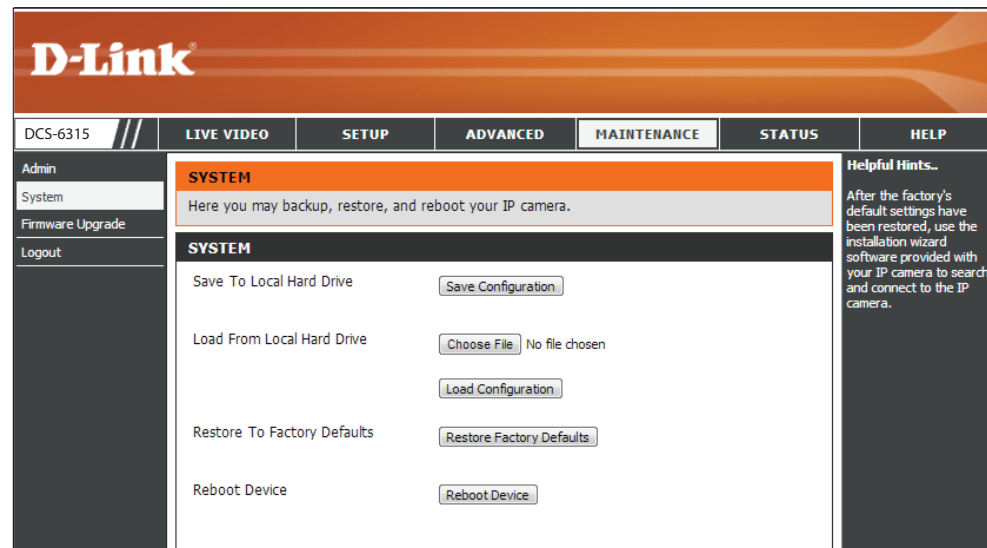

Firmware Upgrade

The camera's current firmware version will be displayed on this screen. Visit the D-Link Support Website to check for the latest available firmware version.

To upgrade the firmware on your DCS-6315, download and save the latest firmware version from the D-Link Support Page to your local hard drive and then upload the firmware.

Current Firmware Version: Displays the detected *Firmware Version*.

Current Product Name: Displays your camera's model name, which is also the *Product Name*.

File Path: Locate the file (upgraded firmware) on your hard drive by clicking **Choose File**.

Upload: Click **Upload** to upgrade the firmware on your camera.

The screenshot shows the D-Link web interface for the DCS-6315 camera. The top navigation bar includes 'LIVE VIDEO', 'SETUP', 'ADVANCED', 'MAINTENANCE', 'STATUS', and 'HELP'. The left sidebar has 'Admin', 'System', 'Firmware Upgrade', and 'Logout'. The main content area is titled 'FIRMWARE UPGRADE' and contains the following text:

A new firmware upgrade may be available for your IP camera. It is recommended to keep your IP camera firmware up-to-date to maintain and improve the functionality and performance of your internet IP camera. Click here [D-Link Support Page](#) to check for the latest firmware version available.

To upgrade the firmware on your IP camera, please download and save the latest firmware version from the D-Link Support Page to your local hard drive. Locate the file on your local hard drive by clicking the Browse button. Once you have found and opened the file using the browse button, click the "Upload" button to start the firmware upgrade.

FIRMWARE INFORMATION

Current Firmware Version:	0.01.00
Current Product Name:	DCS-6314

FIRMWARE UPGRADE

File Path: No file chosen

Helpful Hints... Firmware upgrade are released periodically to improve the functionality of your IP camera and also to add new features. If you run into a problem with a specific feature of the IP camera, check our support site by clicking [here](#) to check for an upgrade and see if updated firmware is available for your IP camera.

Status Device Info

This page displays detailed information about your DCS-6315 and your network connection.

The screenshot shows the D-Link web interface for the DCS-6315 camera. The top navigation bar includes 'LIVE VIDEO', 'SETUP', 'ADVANCED', 'MAINTENANCE', 'STATUS', and 'HELP'. The 'STATUS' tab is active, and the 'Device Info' sub-tab is selected. The main content area is titled 'DEVICE INFO' and contains a summary paragraph and a table of device information.

INFORMATION	
IP camera Name	DCS-6315
Time & Date	Wed Mar 20 11:00:57 2013
Firmware Version	0.01.00
MAC Address	0A:34:CA:6A:CA:0B
IP Address	192.168.0.100
IP Subnet Mask	255.255.255.0
Default Gateway	192.168.0.1
Primary DNS	192.168.0.1
Secondary DNS	0.0.0.0
PPPoE	Disable
DDNS	Disable

Helpful Hints..
This page displays all the information about the IP camera and network settings.

Logs

This page displays the system log information of your DCS-6315.

First Page: Click on **First Page** to go to the first page of the system logs.

Previous 20: Click **Previous 20**, to view the previous 20 events that have occurred.

Next 20: Click **Next 20**, to view the next 20 events that have occurred.

Clear: Click **Clear** to delete the saved log information.

Download: Click **Download** to download the log information.

The screenshot shows the D-Link web interface for device DCS-6315. The top navigation bar includes tabs for LIVE VIDEO, SETUP, ADVANCED, MAINTENANCE, STATUS, and HELP. The left sidebar contains links for Device Info, Log, and Logout. The main content area is titled 'SYSTEM LOG' and contains the following text: 'The system log records IP camera events that have occurred.' Below this is a 'CURRENT LOG' section with a list of 20 entries:

1. 2013-03-20 11:00:23 NETWORK RECONNECT
2. 2013-03-20 11:00:18 Someone Create Certificate
3. 2013-03-20 11:00:17 NETWORK LOSS
4. 2013-03-20 11:00:17 NETWORK RECONNECT
5. 2013-03-20 11:00:07 NETWORK LOSS
6. 2013-03-20 11:00:06 IP CAMERA ACQUIRE DHCP IP 192.168.0.100
7. 2013-03-20 11:00:05 NETWORK RECONNECT
8. 2013-03-20 11:00:04 NETWORK LOSS
9. 2013-03-20 10:57:14 IP CAMERA ACQUIRE DHCP IP 192.168.0.100
10. 2013-03-20 10:57:14 NETWORK RECONNECT
11. 2013-03-20 10:57:12 NETWORK LOSS
12. 2013-03-20 10:55:36 admin LOGIN OK FROM 192.168.0.2
13. 2013-03-20 10:47:10 admin FROM 192.168.0.2 SET VIDEO CODEC Need Reset
14. 2013-03-20 10:47:10 admin FROM 192.168.0.2 SET PROFILE 1 Viewer window area 640x360
15. 2013-03-20 10:47:10 admin FROM 192.168.0.2 SET PROFILE 1 Frame Size 640x360
16. 2013-03-20 10:44:28 IP CAMERA ACQUIRE DHCP IP 192.168.0.100
17. 2013-03-20 10:44:28 NETWORK RECONNECT
18. 2013-03-20 10:44:24 NETWORK LOSS
19. 2013-03-20 10:42:20 IP CAMERA ACQUIRE DHCP IP 192.168.0.100
20. 2013-03-20 10:42:19 NETWORK RECONNECT

At the bottom of the log list, there are five buttons: 'First Page', 'Previous 20', 'Next 20', 'Clear', and 'Download'. On the right side of the interface, there is a 'Helpful Hints...' section with the text: 'You can save the log to your local hard IP camera by clicking the Download button, and you can clear the log by clicking on the Clear button.'

Help

This page provides helpful information regarding camera operation.

The screenshot shows the D-Link DCS-6315 web interface. At the top is the D-Link logo. Below it is a navigation bar with tabs for LIVE VIDEO, SETUP, ADVANCED, MAINTENANCE, STATUS, and HELP. The HELP tab is selected. On the left side, there is a sidebar with 'Help' and 'Logout' links. The main content area is titled 'HELP' and contains a list of links for each menu item: LIVE VIDEO (Camera), SETUP (Setup Wizard, Network Setup, Dynamic DNS, Image Setup, Audio and Video, Preset, Motion Detection, Time and Date, Event Setup, SD Card), ADVANCED (DI and DO, ICR and IR, HTTPS, Access List), MAINTENANCE (Admin, System, Firmware Upgrade), and STATUS (Device Info, Log). At the bottom of the page, there is a 'SECURITY' section.

DCS-6315	LIVE VIDEO	SETUP	ADVANCED	MAINTENANCE	STATUS	HELP
Help Logout	HELP <ul style="list-style-type: none">LIVE VIDEOSETUPMAINTENANCEADVANCEDSTATUS	LIVE VIDEO <ul style="list-style-type: none">Camera	SETUP <ul style="list-style-type: none">Setup WizardNetwork SetupDynamic DNSImage SetupAudio and VideoPresetMotion DetectionTime and DateEvent SetupSD Card	ADVANCED <ul style="list-style-type: none">DI and DOICR and IRHTTPSAccess List	MAINTENANCE <ul style="list-style-type: none">AdminSystemFirmware Upgrade	STATUS <ul style="list-style-type: none">Device InfoLog
SECURITY						

DI/DO Specifications

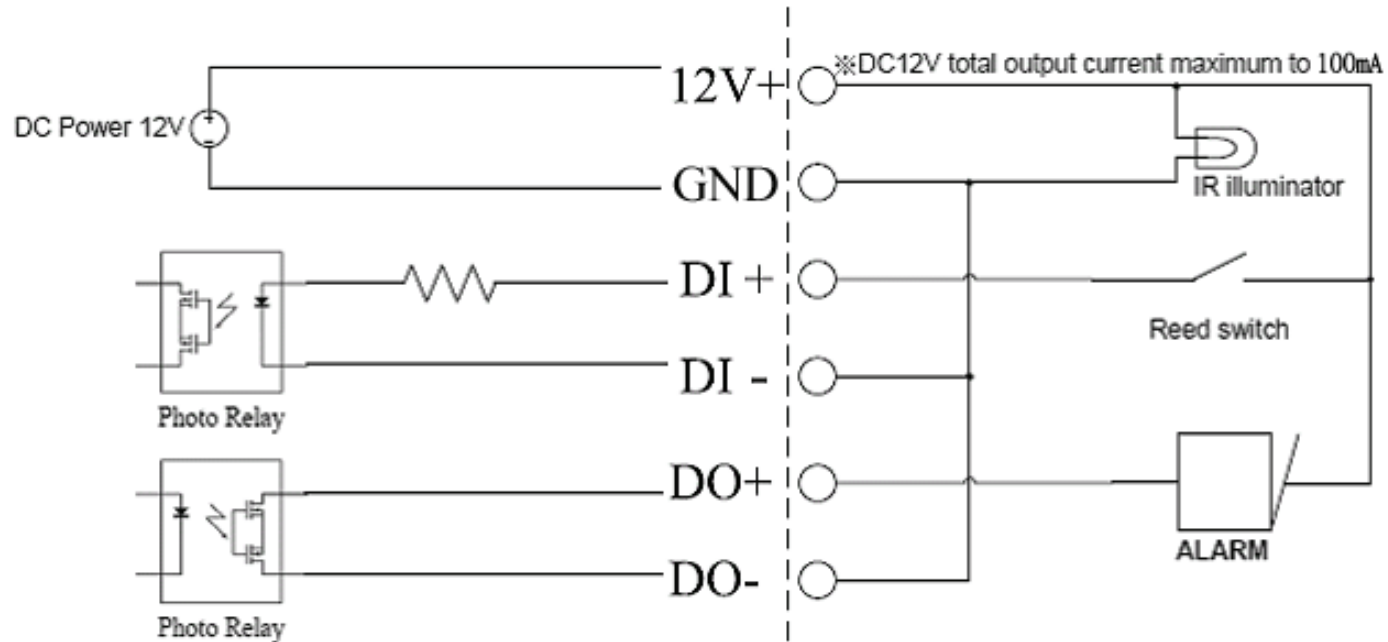



Technical Specifications

Camera	Camera Hardware Profile	<ul style="list-style-type: none"> • 1/3" Megapixel progressive CMOS sensor • 15 meter IR illumination distance • Minimum illumination 0.1 Lux / F1.4 Color mode • Minimum illumination 0.02 Lux / F1.4 Black and White mode • Minimum illumination 0 Lux Black and White mode with IR LED on • Removable (ICR) Filter module 	<ul style="list-style-type: none"> • 2.8 to 12mm variable focal lens • Aperture F1.4 • Angle of view (16:9) <ul style="list-style-type: none"> • (H) 90° ~ 28° • (V) 58.8° ~ 16° • (D) 103° ~ 33° • Minimum object distance 0.2 M
	Camera Housing	<ul style="list-style-type: none"> • IP68 compliant weatherproof housing • IK-10 compliant vandal-proof housing 	<ul style="list-style-type: none"> • Included weather shield
	Image Features	<ul style="list-style-type: none"> • Configurable image size, quality, frame rate, and bit rate • Time stamp and text overlays • Configurable motion detection windows 	<ul style="list-style-type: none"> • Configurable privacy mask zones • Configurable exposure time, brightness, saturation, contrast, sharpness.
	Video Compression	<ul style="list-style-type: none"> • Simultaneous H.264/MPEG-4/MJPEG format compression • H.264/MPEG-4 multicast streaming 	<ul style="list-style-type: none"> • JPEG for still images
	Video Resolution	<ul style="list-style-type: none"> • 16:9 - 1280 x 720, 800 x 450, 640 x 360, 480 x 270, 320 x 176 up to 30 fps 	<ul style="list-style-type: none"> • 4:3 - 1024 x 768, 800 x 600, 640 x 480, 320 x 240 up to 30 fps
	Audio Support	<ul style="list-style-type: none"> • G.726 	<ul style="list-style-type: none"> • G.711
	External Device Interface	<ul style="list-style-type: none"> • 10/100 BASE-TX Ethernet port with PoE • 1 DI / 1 DO • DC12V, 100 mA Output 	<ul style="list-style-type: none"> • micro SD/SDHC/SDXC card Slot, accepts cards up to 64 GB • Audio input / output
Network	Network Protocols	<ul style="list-style-type: none"> • IPv6 • IPv4 • TCP/IP • UDP • ICMP • DHCP client • NTP client (D-Link) • DNS client • DDNS client (D-Link) • SMTP client • FTP client 	<ul style="list-style-type: none"> • HTTP / HTTPS • Samba client • PPPoE • UPnP port forwarding • RTP / RTSP / RTCP • IP filtering • QoS • CoS • Multicast • ONVIF compliant • SNMP
	Security	<ul style="list-style-type: none"> • Administrator and user group protection • Password authentication 	<ul style="list-style-type: none"> • HTTP and RTSP authentication

Appendix A: Technical Specifications

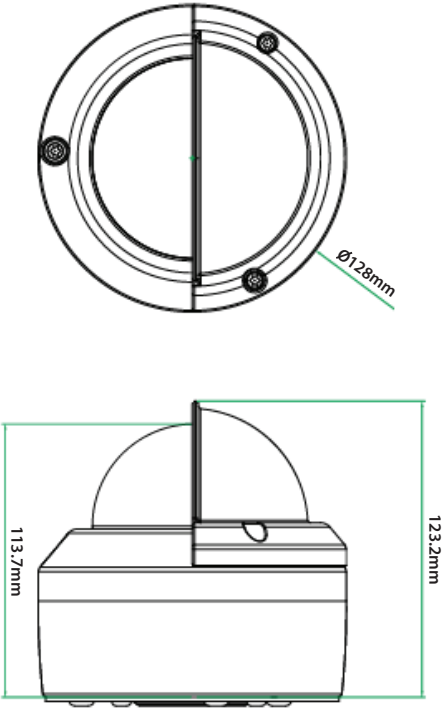
System Management	System Requirements for Web Interface	<ul style="list-style-type: none"> • Browser: Internet Explorer, Firefox, Chrome, Safari 	
	Event Management	<ul style="list-style-type: none"> • Motion detection • Event notification and uploading of snapshots/video clips via e-mail or FTP 	<ul style="list-style-type: none"> • Supports multiple SMTP and FTP servers • Multiple event notifications • Multiple recording methods for easy backup
	Remote Management	<ul style="list-style-type: none"> • Take snapshots/video clips and save to local hard drive 	<ul style="list-style-type: none"> • Configuration interface accessible via web browser
	OS Support	<ul style="list-style-type: none"> • Windows 2000/XP/Vista/Windows 7/8 	
	D-ViewCam™ System Requirements	<ul style="list-style-type: none"> • Operating System: Microsoft Windows 7/Vista/XP • Web Browser: Internet Explorer 7 or higher 	<ul style="list-style-type: none"> • Protocol: Standard TCP/IP
	D-ViewCam™ Software Functions	<ul style="list-style-type: none"> • Remote management/control of up to 32 cameras • Viewing of up to 32 cameras on one screen 	<ul style="list-style-type: none"> • Supports all management functions provided in web interface • Scheduled motion triggered, or manual recording options
General	Weight	<ul style="list-style-type: none"> • 1112g (with weathershield) 	
	External Power Adapter	<ul style="list-style-type: none"> • Input: 100~240 V AC , 50/60 Hz 	<ul style="list-style-type: none"> • Output: 12 V DC 1.5 A
	Power Consumption	<ul style="list-style-type: none"> • 12.24 +-5% Watt 	
	Temperature	<ul style="list-style-type: none"> • Operating: -30 to 50 °C (-22 to 122 °F) 	<ul style="list-style-type: none"> • Storage: -20° to 70° C (-4° to 158° F)
	Humidity	<ul style="list-style-type: none"> • Operating: 20% to 80% non-condensing 	<ul style="list-style-type: none"> • Storage: 5% to 95% non-condensing
	Certifications	<ul style="list-style-type: none"> • CE • CE LVD 	<ul style="list-style-type: none"> • FCC • C-Tick

<p>Dimensions</p>			
<p>Order Information</p>	<p>Part Number</p>	<p>Description</p>	
<p>Optional Accessories</p>	<p>DCS-34-2</p>		<p>Pendant Mount 201 x 150 mm (7.9 x 5.9 inches), 665 grams (1.45 lbs)</p>
	<p>DCS-34-3</p>		<p>Bent Arm Mount 253 x 150 mm (9.96 x 5.9 inches), 770 grams (1.7 lbs)</p>